

CF/14

The **CF/14** is the PF's filter used to **protect the pilot circuit of natural gas pressure regulators and instrumentation**. It is mainly used to remove solid contaminants generated under certain pressure and temperature conditions, leading to the pilot circuit's clogging. **CF/14** helps to **increase the regulators performance and reduce the maintenance**.



Features	Values
Design pressure*	up to 10.2 MPa up to 1479 psig
Ambient temperature*	from -20 °C to +60 °C from -4 °F to +140 °F
Gas temperature range*	from -20 °C to +60 °C from -4 °F to +140 °F
Filtered gases	Natural gas, 20% hydrogen blend, biomethane
Removed contaminants	Elemental sulfur, powder
Filtration degree	Up to 20 microns
Inlet and outlet connections	1/4" FNPT

(* NOTE: Different functional features and/or extended temperature ranges available on request. Stated temperature ranges are the maximum for the equipment's full performance. Standard product may have a narrower range.

Table 1 Features

Materials and Approvals

Part	Material
Construction material	Carbon steel
Sealing	Nitrile rubber
Filter material	Stainless steel

NOTE: The materials indicated above refer to the standard models.

Table 2 Materials

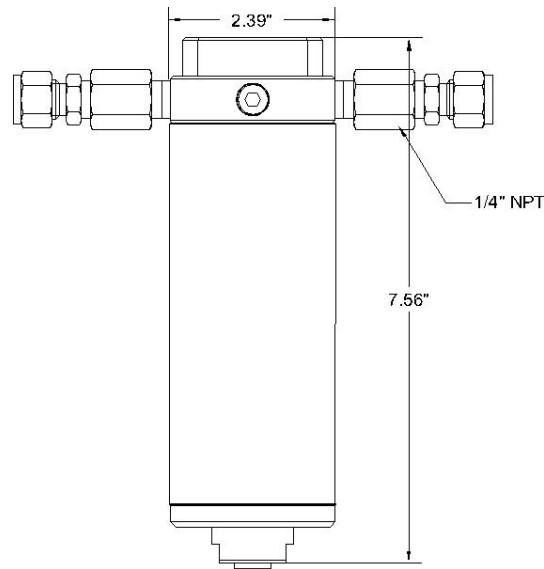

CF/14 competitive advantages



Simplified cartridge swaps



Easy maintenance



Robust cartridge design



Biomethane and up to 20% hydrogen blending compatible