

# HBC 975

Slam-shut valve



Revision 00 - Edition 09/2021

**USE, MAINTENANCE  
AND WARNING  
MANUAL**



# 1 - INTRODUCTION

## FOREWORD

All rights reserved. No part of this publication may be reproduced, distributed, translated into other languages or transmitted by any electronic or mechanical media, including photocopies, recording or any other storage and retrieval system, for any other purposes that are not exclusively the personal use of the buyer, without the express written permission of the Manufacturer.

The manufacturer is in no way responsible for the consequences of operations carried out in a manner not in accordance with the manual.

## GENERAL CONSIDERATIONS

All operating, maintenance instructions and recommendations described in this manual must be observed. In order to obtain the best performance and to keep the equipment in efficient condition, the manufacturer recommends that maintenance operations be carried out regularly.

It is of particular importance that the personnel responsible for the equipment be trained in its use, maintenance and application of the safety instructions and procedures indicated in this manual.

Revision: 00  
Edition: 09/2021



## 1.1 - REVISION HISTORY

Revision index	Edition	Revision contents
00	09/2021	

Tab. 1.1.

## INDEX

<b>1 - INTRODUCTION .....</b>	<b>3</b>
1.1 - REVISION HISTORY.....	5
<b>2 - GENERAL INFORMATION .....</b>	<b>11</b>
2.1 - MANUFACTURER IDENTIFICATION .....	11
2.2 - IDENTIFICATION OF THE PRODUCT .....	11
2.3 - REGULATORY FRAMEWORK.....	11
2.4 - WARRANTY .....	11
2.5 - SYMBOLS USED IN THE MANUAL.....	12
2.6 - ADDRESSEES, SUPPLY AND STORAGE OF THE MANUAL .....	13
2.7 - LANGUAGE .....	13
2.8 - NAMEPLATES APPLIED .....	14
2.8.1 - GLOSSARY FOR NAMEPLATES .....	15
2.9 - GLOSSARY OF MEASUREMENT UNITS.....	16
2.10 - QUALIFIED PROFESSIONAL FIGURES.....	17
<b>3 - SAFETY .....</b>	<b>19</b>
3.1 - GENERAL SAFETY INSTRUCTIONS .....	19
3.2 - PERSONAL PROTECTIVE EQUIPMENT.....	20
3.3 - RESIDUAL RISKS .....	21
3.3.1 - TABLE SHOWING RESIDUAL RISKS DUE TO PRESSURE .....	22
3.3.2 - TABLE OF RESIDUAL RISKS FOR POTENTIALLY EXPLOSIVE ATMOSPHERES .....	24
3.4 - OBLIGATIONS AND PROHIBITIONS .....	26
3.5 - SAFETY PICTOGRAMS .....	27
3.6 - RISK LEVEL .....	27

## **4 - DESCRIPTION AND OPERATION ..... 28**

4.1 - GENERAL DESCRIPTION .....	28
4.2 - OPERATION.....	30
4.3 - INTENDED USE .....	31
4.3.1 - ENVISAGED USE .....	31
4.3.2 - REASONABLY FORESEEABLE MISUSE .....	31
4.3.3 - TYPES OF FLUIDS .....	31
4.4 - TECHNICAL FEATURES/PERFORMANCE .....	32
4.4.1 - SLAM-SHUT VALVE PRESSURE SWITCHES .....	34

## **5 - TRANSPORT AND HANDLING ..... 37**

5.1 - SPECIFIC WARNINGS FOR TRANSPORT AND HANDLING .....	37
5.1.1 - PACKAGING AND FASTENERS USED FOR TRANSPORT .....	38
5.2 - PHYSICAL CHARACTERISTICS OF THE EQUIPMENT .....	39
5.3 - ANCHORING AND LIFTING METHOD.....	40
5.3.1 - FORKLIFT HANDLING METHOD.....	41
5.3.2 - CRANE HANDLING METHOD.....	43
5.4 - PACKAGING REMOVAL.....	44
5.4.1 - PACKAGING DISPOSAL .....	44
5.5 - STORAGE AND ENVIRONMENTAL CONDITIONS .....	45
5.5.1 - PRE-INSTALLATION WARNINGS AFTER PROLONGED STORAGE .....	45

## **6 - INSTALLATION ..... 47**

6.1 - INSTALLATION PRE-REQUISITES.....	47
6.1.1 - ENVIRONMENTAL CONDITIONS ALLOWED.....	47
6.1.2 - CHECKS BEFORE INSTALLATION.....	48
6.2 - SPECIFIC SAFETY INSTRUCTIONS FOR THE INSTALLATION STEP .....	49
6.3 - GENERAL INFORMATION ON CONNECTIONS .....	50
6.4 - EQUIPMENT INSTALLATION POSITIONS .....	51
6.5 - INSTALLATION PROCEDURES.....	52
6.5.1 - IN-LINE EQUIPMENT INSTALLATION PROCEDURE .....	52
6.5.2 - CONNECTION OF THE SENSING LINES TO THE DOWNSTREAM PIPING.....	52
6.6 - POST-INSTALLATION AND PRE-COMMISSIONING CHECKS .....	54

## **7 - COMMISSIONING AND MAINTENANCE EQUIPMENT ..... 55**

- 7.1 - LIST OF REQUIRED EQUIPMENT ..... 55
- 7.2 - EQUIPMENT NEEDED FOR THE DIFFERENT CONFIGURATIONS ..... 57

## **8 - COMMISSIONING ..... 59**

- 8.1 - GENERAL WARNINGS ..... 59
  - 8.1.1 - SAFETY REQUIREMENTS FOR COMMISSIONING ..... 59
- 8.2 - PRELIMINARY PROCEDURES FOR COMMISSIONING ..... 60
- 8.3 - PROPER COMMISSIONING CHECK ..... 61
- 8.4 - CALIBRATION OF ANY ACCESSORIES ..... 61
- 8.5 - PROCEDURE FOR COMMISSIONING THE EQUIPMENT ..... 62
  - 8.5.1 - PROCEDURE FOR CHECKING THE SLAM-SHUT VALVE FOR SEALING ..... 62
  - 8.5.2 - CALIBRATION PROCEDURE FOR PRESSURE SWITCHES MOD. 100 FOR LINE OFF 2.0 ..... 64
    - 8.5.2.1 - CALIBRATION PROCEDURE WITHOUT MAIN REGULATOR ..... 64
    - 8.5.2.2 - CALIBRATION PROCEDURE WITH MAIN REGULATOR ..... 66
  - 8.5.3 - PROCEDURE FOR COMMISSIONING THE EQUIPMENT WITH LINE OFF 2.0 ..... 68

## **9 - MAINTENANCE AND FUNCTIONAL CHECKS ..... 71**

- 9.1 - GENERAL WARNINGS ..... 71
- 9.2 - PERIODICALLY CHECKING AND INSPECTING THE EQUIPMENT FOR PROPER OPERATION ..... 73
- 9.3 - ROUTINE MAINTENANCE ..... 74
  - 9.3.1 - GENERAL SAFETY WARNINGS ..... 74
  - 9.3.2 - REPLACEMENT FREQUENCY FOR COMPONENTS SUBJECT TO WEAR ..... 75
- 9.4 - ROUTINE MAINTENANCE PROCEDURES ..... 77
  - 9.4.1 - TIGHTENING TORQUES FOR HB/975 BUILT-IN SLAM-SHUT VALVE WITH LINE OFF 2.0 ..... 78
  - 9.4.2 - REPLACING ELEMENTS SUBJECT TO WEAR AND ABRASION ..... 89
  - 9.4.3 - LINE OFF 2.0 DISCONNECTION PROCEDURE ..... 90
  - 9.4.4 - HBC 975 BUILT-IN SLAM-SHUT VALVE MAINTENANCE PROCEDURE ..... 92
  - 9.4.5 - LINE OFF 2.0 MAINTENANCE PROCEDURE ..... 106
  - 9.4.6 - MAINTENANCE PROCEDURE FOR PRESSURE SWITCHES MODELS 102M/102MH - 105M/105MH122 ..... 140
  - 9.4.7 - LINE OFF 2.0 RECONNECTION PROCEDURE ..... 140
  - 9.4.8 - PROCEDURE FOR RECOMMISSIONING AFTER MAINTENANCE ..... 141



**10 - TROUBLESHOOTING..... 143**

10.1 -GENERAL WARNINGS .....	143
10.2 -OPERATOR QUALIFICATION SPECIFICATION .....	144
10.3 -TROUBLESHOOTING PROCEDURES .....	144
10.4 -HBC 975 TROUBLESHOOTING TABLES.....	145

**11 - UNINSTALLATION AND DISPOSAL ..... 149**

11.1 -GENERAL SAFETY WARNINGS.....	149
11.2 -QUALIFICATION OF THE OPERATORS IN CHARGE.....	149
11.3 -UNINSTALLATION.....	149
11.4 -INFORMATION REQUIRED IN CASE OF RE-INSTALLATION.....	149
11.5 -DISPOSAL INFORMATION.....	150

**12 - RECOMMENDED SPARE PARTS ..... 151**

12.1 -GENERAL WARNINGS .....	151
12.2 -HOW TO REQUEST SPARE PARTS.....	151

**13 - CALIBRATION TABLES ..... 153**

13.1 -CALIBRATION TABLES FOR PRESSURE SWITCHES MOD. 100.....	153
--	-----



## 2 - GENERAL INFORMATION

### 2.1 - MANUFACTURER IDENTIFICATION

<b>Manufacturer</b>	PIETRO FIORENTINI S.P.A.
<b>Address</b>	Via Enrico Fermi, 8/10 36057 Arcugnano (VI) - ITALY <b>Tel. +39 0444 968511 Fax +39 0444 960468</b> <b>www.fiorentini.com sales@fiorentini.com</b>

Tab. 2.2.

### 2.2 - IDENTIFICATION OF THE PRODUCT

<b>Equipment</b>	SLAM-SHUT VALVE
<b>Model</b>	HBC 975

Tab. 2.3.

### 2.3 - REGULATORY FRAMEWORK

PIETRO FIORENTINI S.P.A. with registered offices in Arcugnano (Italy) - Via E. Fermi, 8/10, declares under its sole responsibility that the equipment of the HBC 975 series described in this manual is designed, manufactured, tested and checked in compliance with the requirements of the EN 14382 standard.

The equipment meets the requirements of Directive 2014/68/EU (safety accessory as per PED directive). The assessment procedure adopted is in accordance with module H1 according to Annex III of the Directive.

#### **NOTE!**

**The declaration of conformity in its original version is delivered together with the equipment and this operating and warning manual.**

### 2.4 - WARRANTY

PIETRO FIORENTINI S.P.A. guarantees that the equipment was manufactured using the best materials, with high quality workmanship, and complies with the quality requirements, specifications and performance set out in the order.



The warranty shall be considered null and void and PIETRO FIORENTINI S.P.A. shall not be liable for any damage and/or malfunctions:

- due to any acts or omissions of the purchaser or end-user, or any of their carriers, employees, agents, or any third party or entity;
- in the event that the purchaser, or a third party, makes changes to the equipment supplied by PIETRO FIORENTINI S.P.A. without the prior written approval of the latter;
- in the event of failure by the purchaser to comply with the instructions contained in this manual, as provided by PIETRO FIORENTINI S.P.A.

#### **NOTE!**

**The warranty conditions are specified in the commercial contract.**

## 2.5 - SYMBOLS USED IN THE MANUAL

Symbol	Definition
	Symbol used to identify important warnings for the safety of the operator and/or equipment.
	Symbol used to identify information of particular importance in the manual. The information may also concern the safety of the personnel involved in using the equipment.
	Obligation to consult the instruction manual/booklet. Refers to a requirement for personnel to refer to (and understand) the operating and warning instructions of the machine before working with or on it.

Tab. 2.4.

### **HAZARD!**

Alerts to a hazard with a high level of risk, an imminent hazardous situation which, if not prevented, will result in death or severe damage.

### **WARNING!**

Alerts to a hazard with a medium level of risk, a potentially hazardous situation which, if not prevented, may result in death or severe damage.

### **ATTENTION!**

Alerts to a hazard with a low level of risk, a potentially hazardous situation which, if not prevented, could result in minor or moderate damage.

### **NOTE!**

Alerts to specific warnings, directions or notes of particular concern, that are not related to physical injury, as well as practices for which physical injury is not likely to occur.

## 2.6 - ADDRESSEES, SUPPLY AND STORAGE OF THE MANUAL

The manual is intended for the qualified technician responsible for operating and managing the equipment throughout its technical life.

It contains the necessary information for the correct use of the equipment in order to maintain its functional and qualitative characteristics over time. All information and warnings for correct use in full safety are also provided.

The manual, as well as the declaration of conformity and/or test certificate, is an integral part of the equipment and must always accompany it whenever it is moved or resold. It is up to the user to keep this documentation intact for reference throughout the lifespan of the equipment.

### **WARNING!**

**Removing, rewriting or modifying the pages of the manual and their contents is not allowed.**

**Keep the manual near the equipment, in an accessible place known by all qualified technicians involved in using and running it.**

**PIETRO FIORENTINI S.p.A. shall not be held liable for any damage to people, animals and property caused by failure to adhere to the warnings and operating procedures described in this manual.**

## 2.7 - LANGUAGE

The original manual has been drawn up in Italian.

Any translations into additional languages must be made from the original manual.

### **HAZARD!**

**The translations into other languages cannot be fully verified. If any inconsistency is found, please refer to the text of the original manual.**

**If inconsistencies are found or the text does not make sense:**

- stop any actions;
- **immediately contact PIETRO FIORENTINI S.p.A. at the addresses specified in paragraph 2.1.**

### **WARNING!**

**PIETRO FIORENTINI S.p.A. shall be held liable for the information provided in the original manual only.**

## 2.8 - NAMEPLATES APPLIED



### WARNING!

**Removing nameplates and/or replacing them with other plates is strictly not allowed. Should the plates be unintentionally damaged or removed, the customer must notify PIETRO FIORENTINI S.p.A.**

The equipment and its accessories are provided with nameplates (from Id.1 to Id.3).

The plates specify identification details of the equipment and its accessories to be mentioned in case of need to PIETRO FIORENTINI S.p.A.

Table 2.5 shows the identification plates applied:

Id.	Type	Image
1	EQUIPMENT NAMEPLATE (EC version)	
2	SLAM-SHUT VALVE NAMEPLATE	
3	PRESSURE SWITCH NAMEPLATE	

Tab. 2.5.

## 2.8.1 - GLOSSARY FOR NAMEPLATES

The terms and abbreviations used on the nameplates are described below:

Term	Description
<b>CA</b>	Accuracy class.
<b>AG max</b>	Slam-shut valve accuracy class due to pressure increase. "OPSO" (Over pressure shut off).
<b>AG min</b>	Slam-shut valve accuracy class due to pressure decrease. "UPSO"(Under pressure shut off).
<b>bpu</b>	Range of inlet pressure for which the regulator ensures a given accuracy class.
<b>CE</b>	Mark certifying compliance with applicable European directives.
<b>Cg</b>	Flow rate coefficient.
<b>Class</b>	Alphanumeric designation used for references purposes related to a combination of mechanical and dimensional characteristics for flanges, in accordance with the relevant parts of EN 1759 series, which includes the word Class followed by a dimensionless whole number.
<b>DN</b>	Nominal size of connections.
<b>Fail safe mode</b>	Regulator reaction mode (Fail open or Fail close).
<b>Flange</b>	Type of flanged connections or type of connection thread.
<b>Fluid</b>	Type of fluid compatible with the equipment.
<b>ID no.</b>	Number of the Notified Body participating in the conformity assessment of the equipment.
<b>Pilot</b>	Pilot family.
<b>PS</b>	Maximum permissible pressure for which the equipment was designed.
<b>PSD</b>	Specific maximum permissible pressure for which the equipment was designed.
<b>Pu (Up)</b>	Upstream pressure.
<b>Pumax</b>	Maximum inlet pressure at which the regulator can operate continuously under specific conditions.
<b>REGULATOR</b>	Equipment family.
<b>SG</b>	Lock-up pressure class.
<b>Slam-shut device</b>	Slam-shut valve family.
<b>S.n.</b>	Equipment serial number.
<b>Strength type</b>	Strength class: integral strength (IS) or differential strength (DS).
<b>TS</b>	Permissible temperature range (min. and max.) for which the equipment is designed.
<b>Triggering unit</b>	Pressure switch family.
<b>Type</b>	Accessory type and family.
<b>Wd</b>	Full range of set points that can be obtained from the regulator by adjusting and/or replacing certain components (e.g. replacement of valve seat or control element, e.g. spring).
<b>Wdo</b>	Full setpoint range as a result of tripping caused by pressure increase in the pressure switch incorporated in the slam-shut valve. This range can be obtained by adjusting and/or replacing the components (for example, spring or sensitive element).
<b>Wds</b>	Full range of set points that can be obtained from the regulator by adjustment and without replacement of its components.
<b>Wdso</b>	Full setpoint range as a result of tripping caused by pressure increase in the pressure switch incorporated in the slam-shut valve. This range can be obtained by adjusting but not replacing the components.

Term	Description
<b>Wdu</b>	Full setpoint range as a result of triggering caused by pressure decrease of the pressure switch incorporated in the slam-shut valve. This range can be obtained by adjusting and/or replacing the components (for example, spring or sensitive element).
<b>Wdsu</b>	Full setpoint range as a result of tripping caused by pressure decrease in the pressure switch built in the slam-shut valve. This range can be obtained by adjusting but not replacing the components.

Tab. 2.6.

## 2.9 - GLOSSARY OF MEASUREMENT UNITS

Type of measurement	Unit of measurement	Description
<b>Volumetric flow rate</b>	Stm <sup>3</sup> /h	Standard cubic metres per hour
	Scfh	Standard cubic feet per hour
<b>Pressure</b>	bar	Unit of measurement in the CGS system
	psi	Pounds per square inch
	"wc	water column inch
	Pa	Pascal
<b>Temperature</b>	°C	Degree centigrade
	°F	Fahrenheit Degree
	K	Kelvin
<b>Tightening torque</b>	Nm	Newton metro
	ft-lbs	Foot per pound
<b>Sound pressure</b>	dB	Decibel
<b>Other measures</b>	V	Volt
	W	Watt
	Ω	Ohm

Tab. 2.7.



## 2.10 - QUALIFIED PROFESSIONAL FIGURES

Qualified operators in charge of using and managing the equipment throughout its technical service life.

Professional figure	Definition
<b>Mechanical maintenance technician</b>	<p>Qualified technician able to:</p> <ul style="list-style-type: none"> <li>perform preventive/corrective maintenance operations on all mechanical parts of the equipment subject to maintenance or repair.</li> <li>access all device parts for visual inspection, checking equipment status, making adjustments and calibrations.</li> </ul> <p>The maintenance mechanical technician is not authorised to operate on live electrical systems (if any).</p>
<b>Electrical maintenance technician</b>	<p>Qualified technician able to:</p> <ul style="list-style-type: none"> <li>perform preventive/corrective maintenance operations on all electrical parts of the device subject to maintenance or repair;</li> <li>read wiring diagrams and check the correct functional cycle;</li> <li>perform adjustments and operate on electrical systems for maintenance, repair and replacement of worn parts.</li> </ul> <p>The electrical maintenance technician can operate in the presence of voltage inside electrical panels, junction boxes, control equipment etc. only if he/she is a suitable person (S.P.). For general requirements, refer to the IEC EN 50110-1:2014 standard.</p>
<b>Worker in charge of transport, handling, unloading and placement on site</b>	<p>Qualified operator:</p> <ul style="list-style-type: none"> <li>for the use of lifting equipment;</li> <li>for the handling of materials and equipment.</li> </ul> <p>Lifting and handling of the equipment must be carried out strictly in accordance with the instructions provided by the manufacturer and in compliance with the regulations in force at the place where the equipment is installed.</p>
<b>Installer</b>	<p>Qualified technician able to:</p> <ul style="list-style-type: none"> <li>carry out all the operations necessary to properly install the equipment;</li> <li>perform all the procedures required to properly and safely install the equipment.</li> </ul>
<b>User's technician</b>	<p>Technician trained and authorised to use and manage the equipment for the activities it was supplied for. They must:</p> <ul style="list-style-type: none"> <li>be able to perform all operations required for the proper functioning of the equipment and the system, and for their safety or that of any personnel present;</li> <li>have proven experience in properly using the equipment similar to that described in this manual, and be trained, informed and instructed in this regard.</li> </ul> <p>The technician may carry out maintenance only if authorised/qualified to do so.</p>

Tab. 2.8.



## 3 - SAFETY

### 3.1 - GENERAL SAFETY INSTRUCTIONS

#### WARNING!

The equipment described in this manual is:

- a device subjected to pressure in pressurised systems;
- normally installed in systems carrying flammable gases (for example: natural gas).

#### WARNING!

If the gas used is a combustible gas, the installation area of the equipment is defined as a “danger zone” as there are residual risks that potentially explosive atmospheres may be generated.

There must not be any effective sources of ignition in “danger zones”

- and in close proximity thereto;
- no smoking.

#### ATTENTION!

Authorised operators must not carry out operations or services on their own initiative that do not fall within their competence.

Never operate the equipment:

- while under the influence of intoxicating substances such as alcohol;
- if you are using drugs that may lengthen reaction times.

#### NOTE!

The employer must train and inform operators on how to behave during operations and on the equipment to be used.

Before installation, commissioning or maintenance, operators must:

- take note of the safety regulations applicable to the place of installation that they are working in;
- obtain the necessary permits to operate when required;
- equip themselves with the necessary personal protection required in the procedures described in this manual;
- ensure that the area that they are operating in is equipped with the required collective protections and the necessary safety information.

### 3.2 - PERSONAL PROTECTIVE EQUIPMENT

Table 3.9 shows the Personal Protective Equipment (PPE) and its description. An obligation is associated with each symbol.

Personal protective equipment means any equipment intended to be worn by the worker in order to protect them against one or several risks that are likely to threaten their safety or health during work.

For the operators in charge, depending on the type of work requested, the most appropriate PPE of the following will be reported and must be used:

Symbol	Meaning
	<b>Obligation to use safety or insulated gloves.</b> Indicates a requirement for personnel to use safety or insulated gloves.
	<b>Obligation to use safety goggles.</b> Indicates a requirement for personnel to use protective goggles for eye protection.
	<b>Obligation to use safety shoes.</b> Indicates a requirement for personnel to use accident-prevention safety shoes.
	<b>Obligation to use noise protection equipment.</b> Indicates a requirement for personnel to use ear muffs or ear plugs to protect their hearing.
	<b>Obligation to wear protective clothing.</b> Indicates a requirement for personnel to wear specific protective clothing.
	<b>Obligation to use a protective mask.</b> Indicates a requirement for personnel to use respiratory masks in the event of a chemical risk.
	<b>Obligation to use a protective helmet.</b> Indicates a requirement for personnel to use the protective helmet.
	<b>Obligation to wear a high visibility vest.</b> Indicates a requirement for personnel to use a high visibility vest.

Tab. 3.9.

#### **WARNING!**

Each licensed operator is obliged to:

- take care of their own health and safety and that of other people present in the workplace, who are affected by their actions or omissions, in accordance with their training, instructions and means provided by the employer;
- use the PPE appropriately made available;
- immediately report to the employer, the manager or the person in charge of the deficiencies of the means and devices as well as any possible dangerous conditions of which they become aware.

### **3.3 - RESIDUAL RISKS**

In accordance with the requirements of PED 2014/68/EU, point 1.2 of Annex I, below is an assessment of the risks associated with the equipment and an indication of the principles adopted for their prevention, according to the following classification:

- a) Elimination and/or reduction of the risk.
- b) Application of the appropriate protective measures.
- c) Information to users about residual risks.

### 3.3.1 - TABLE SHOWING RESIDUAL RISKS DUE TO PRESSURE

Risk and Hazard	Event and Cause	Effect and Consequence	Solution and Prevention
<b>Pressurised gas leakage. Projection of metallic and non-metallic pressurised parts.</b>	<ul style="list-style-type: none"> <li>Violent impact;</li> <li>Impact (also due to falling, improper handling, etc.).</li> </ul>	<ul style="list-style-type: none"> <li>Deformation;</li> <li>Broken connections and, if under pressure, even burst.</li> </ul>	<p>a. Handling and installation with appropriate devices to avoid localised stress.</p> <p>b. Installation in suitable places and spaces with appropriate protections, suitable packaging.</p> <p>c. Information in the instructions for use and warning.</p>
<b>Pressurised gas leakage. Projection of metallic and non-metallic pressurised parts.</b>	<ul style="list-style-type: none"> <li>Use of inappropriate fluids.</li> </ul>	<ul style="list-style-type: none"> <li>Corrosion;</li> <li>Embrittlement;</li> <li>Explosion.</li> </ul>	<p>a. The user must check compliance of the used fluid with the specifications on the data plate.</p>
<b>Pressurised gas leakage. Projection of metallic and non-metallic pressurised parts.</b>	<ul style="list-style-type: none"> <li>Operation at temperatures below the minimum permissible temperature.</li> </ul>	<ul style="list-style-type: none"> <li>Embrittlement;</li> <li>Breakage;</li> <li>Explosion.</li> </ul>	<p>a. Install in places where the temperature is not below the minimum permissible temperature and/or insulate the equipment adequately.</p> <p>b. The minimum temperature allowed is indicated on the data plate.</p>
<b>Pressurised gas leakage. Projection of metallic and non-metallic pressurised parts. Explosion.</b>	<ul style="list-style-type: none"> <li>Overpressure or exceeding of the rated limit values (maximum pressure allowed)</li> </ul>	<ul style="list-style-type: none"> <li>Explosion;</li> <li>Breaks;</li> <li>Cracks;</li> <li>Permanent deformations.</li> </ul>	<p>a. The device has appropriate design safety margins.</p> <p>b. The user must check the maximum pressure applicable to the equipment.</p> <p>c. The maximum allowable pressure is highlighted on the appropriate plate on the equipment.</p>
<b>Falling of the equipment.</b>	<ul style="list-style-type: none"> <li>Dangerous handling.</li> </ul>	<ul style="list-style-type: none"> <li>Deformation;</li> <li>Cracking;</li> <li>Breakage.</li> </ul>	<p>a. The user must have suitably sized lifting equipment.</p> <p>b. The above requirements are referred to in the equipment use and warning manual.</p>
<b>Pressurised fluid leakage. Projection of metallic and non-metallic pressurised parts.</b>	<ul style="list-style-type: none"> <li>Incorrect fixing of the equipment.</li> </ul>	<ul style="list-style-type: none"> <li>Deformation;</li> <li>Breakage.</li> </ul>	<p>a. The device is equipped with unified type process connections and compression fittings.</p> <p>b. The user must ensure correct fixing to the line.</p> <p>c. Directions in the instructions for use and warning.</p>
<b>Explosion of the device. Pressurised fluid leakage. Projection of metallic parts.</b>	<ul style="list-style-type: none"> <li>Operation at temperatures above the maximum permissible temperature.</li> </ul>	<ul style="list-style-type: none"> <li>Reduction of mechanical resistance and breakage of the device;</li> <li>Explosion.</li> </ul>	<p>a. The user must equip the system with suitable safety and control devices.</p> <p>b. The maximum temperature allowed is indicated on the data plate.</p>

Risk and Hazard	Event and Cause	Effect and Consequence	Solution and Prevention
<b>Pressurised gas leakage.</b>	<ul style="list-style-type: none"> <li>• Device maintenance with the system running.</li> </ul>	<ul style="list-style-type: none"> <li>• Inappropriate opening of pressurised chambers.</li> </ul>	<p>a. The user must perform any maintenance with the equipment not in operation.</p> <p>b. The above requirements are referred to in the use and warning manual.</p>
<b>Pressurised gas leakage. Projection of metallic and non-metallic pressurised parts.</b>	<ul style="list-style-type: none"> <li>• External loads bearing on the device.</li> </ul>	<ul style="list-style-type: none"> <li>• Deformation;</li> <li>• Cracking and slot formation;</li> <li>• If under pressure, even burst.</li> </ul>	<p>a. With the exclusion of what is set out in the project, the user must verify that no additional concentrated load bears on the device.</p>
<b>Pressurised gas leakage. Projection of metallic and non-metallic pressurised parts.</b>	<ul style="list-style-type: none"> <li>• Electrostatic potential, differential stray currents.</li> </ul>	<ul style="list-style-type: none"> <li>• Corrosion localised in the device.</li> </ul>	<p>b. The user must equip the device with the necessary protection and earthing devices.</p> <p>c. The above requirements are referred to in the use and warning manual.</p>
<b>Pressurised gas leakage. Projection of metallic and non-metallic pressurised parts.</b>	<ul style="list-style-type: none"> <li>• Humidity;</li> <li>• Environments with aggressive atmosphere.</li> </ul>	<ul style="list-style-type: none"> <li>• Deterioration of external surfaces;</li> <li>• Corrosion.</li> </ul>	<p>a. The user must periodically check the state of conservation of the external surfaces.</p> <p>b. The above requirements are referred to in the use and warning manual.</p>

Tab. 3.10.

### 3.3.2 - TABLE OF RESIDUAL RISKS FOR POTENTIALLY EXPLOSIVE ATMOSPHERES

Table 3.11 indicates the conditions that can cause the HBC 975 slam-shut valve to generate a potentially explosive atmosphere.

The table is valid for use with natural gas with a density of no more than 0.8; for different densities, the installation and environmental conditions must also be evaluated.

#### **WARNING!**

**If the gas used is a combustible gas, the installation area of the equipment is defined as a “danger zone” as there are residual risks that potentially explosive atmospheres may be generated.**

**There must be no effective sources of ignition in “danger zones” and in close proximity thereto.**

Operating conditions	Potentially explosive atmosphere	Regulatory references	Management measures included in the instructions for use and warning
<b>First start-up</b>	No	<ul style="list-style-type: none"> <li>During the production cycle and before the CE marking according to Directive 2014/68/EU, the external tightness of the equipment is checked at a value of 1.1 PS, in accordance with Standard EN 14382.</li> <li>Before commissioning, the external sealing of the system portion on which the equipment is installed is checked at a suitable pressure (in accordance with the provisions of standards EN 12186 and EN 12279).</li> </ul>	The instructions for use indicate the need to meet the requirements of Standards EN 12186 and EN 12279.
<b>Operation in normal conditions</b>	No	<p>The indications in the previous point apply, in addition:</p> <ul style="list-style-type: none"> <li>the equipment is installed outdoors or in an environment with natural ventilation (in accordance with Standards EN 12186 and EN 12279);</li> <li>the installation is subject to surveillance according to current national rules/good practice/the equipment manufacturer's instructions (in accordance with the provisions of Standard EN 12186 and Standard EN 12279).</li> </ul>	<p>The instructions for use indicate that:</p> <ul style="list-style-type: none"> <li>any environment in which the equipment is installed must meet the requirement of Standards EN 12186 and EN 12279;</li> <li>periodic checks and maintenance must be carried out during surveillance in accordance with the national rules in force (if any), and with the specific manufacturer's recommendations.</li> </ul>
<b>Breakage of the pressure switch diaphragm (malfunction)</b>	No	<p>This event must be considered a rare malfunction.</p> <p>All atmospheric pressure chambers delimited on at least one side by a diaphragm must be channelled to a safe area (in accordance with the provisions of Standard EN 12186 and Standard EN 12279).</p>	The instructions for use indicate the need to meet the requirements of Standards EN 12186 and EN 12279.
<b>Breakage of other non-metallic parts (malfunction)</b>	No	This type of malfunction is not reasonably expected as it involves static sealing (to the outside).	-



Operating conditions	Potentially explosive atmosphere	Regulatory references	Management measures included in the instructions for use and warning
<b>Decommissioning</b>	No	<ul style="list-style-type: none"> <li>The pressure of the system section in which the equipment is installed must be reduced with appropriate vent lines channelled to a safe area (in accordance with the provisions of Standard EN 12186 and Standard EN 12279).</li> <li>The residual gas must be discharged as indicated above.</li> </ul>	The instructions for use indicate the need to meet the requirements of Standards EN 12186 and EN 12279
<b>Restart</b>	No	<ul style="list-style-type: none"> <li>After reassembling the equipment, carry out an external leakage test at a suitable pressure value, as specified by the manufacturer.</li> <li>Before commissioning, the external sealing of the system portion on which the equipment is installed is checked at a suitable pressure (in accordance with the provisions of standards EN 12186 and EN 12279).</li> </ul>	The instructions for use indicate: <ul style="list-style-type: none"> <li>the minimum conditions for testing internal leakage;</li> <li>the need to meet the requirements of Standards EN 12186 and EN 12279.</li> </ul>

Tab. 3.11.

### 3.4 - OBLIGATIONS AND PROHIBITIONS

The following is a list of obligations and prohibitions to be observed for the safety of the operator:



- carefully read and understand the instructions for use and warning;
- The downstream equipment must be suitably sized according to the equipment performance required in the actual operating condition;
- before installing the equipment, the data on the nameplates must be checked;
- avoid violent shocks and impacts that could damage the equipment and cause the pressure fluid to escape.

It is strictly forbidden to:

- operate in various capacities on the equipment without the PPE indicated in the work procedures described in these use and warning instructions;
- operate in the presence of open flames or bring open flames close to the work area;
- smoke near the equipment or while working on it;
- use the equipment with parameters other than those indicated on the nameplate;
- use the equipment with fluids other than those indicated on the nameplate and in these use and warning instructions;
- use the equipment outside the operating temperature range declared on the identification plate and in these use and warning instructions;
- service the equipment with the portion of the system on which it is installed in operation;
- install or use the equipment in environments not specified in this manual.

### 3.5 - SAFETY PICTOGRAMS

The following safety pictograms may be shown on the equipment and/or packaging PIETRO FIORENTINI S.p.A.:

Symbol	Definition
	Symbol used to identify an ELECTRICAL HAZARD.
	Symbol used to identify a GENERIC HAZARD.

Tab. 3.12.

#### HAZARD!

**It is absolutely forbidden to remove the safety pictograms on the equipment.**

**The user is required to replace the safety pictograms which, following wear, removal or tampering, are illegible.**

### 3.6 - RISK LEVEL

Depending on the operating conditions, use and configuration required, the equipment may generate noise beyond the limits allowed by current legislation in the country of installation.

For the value of the noise generated by the equipment and further information, contact PIETRO FIORENTINI S.p.A.

#### ATTENTION!

**The obligation to use headphones or ear plugs to protect the operator's hearing remains in the event that the noise in the installation environment of the equipment (depending on specific operating conditions) exceeds the value of 85 dBA.**

## 4 - DESCRIPTION AND OPERATION

### 4.1 - GENERAL DESCRIPTION

The HBC 975 slam-shut valve is a safety device that shuts off gas if the controlled pressure reaches the calibration value set for its tripping.

The HBC 975 slam-shut valve can be installed in a line upstream of a regulator, or individually.

If the slam-shut valve is mounted upstream of the regulator, the control pressure reaching the pressure switch is taken downstream of the regulator.

If the valve is mounted individually, the pressure switch takes the pressure downstream of the slam-shut valve.

The HBC 975 built-in slam-shut valve consists of (see fig. 4.1):

Pos.	Description
1	Balanced valve plug
2	Single acting pneumatic actuator
3	LINE OFF 2.0 device

Tab. 4.13.

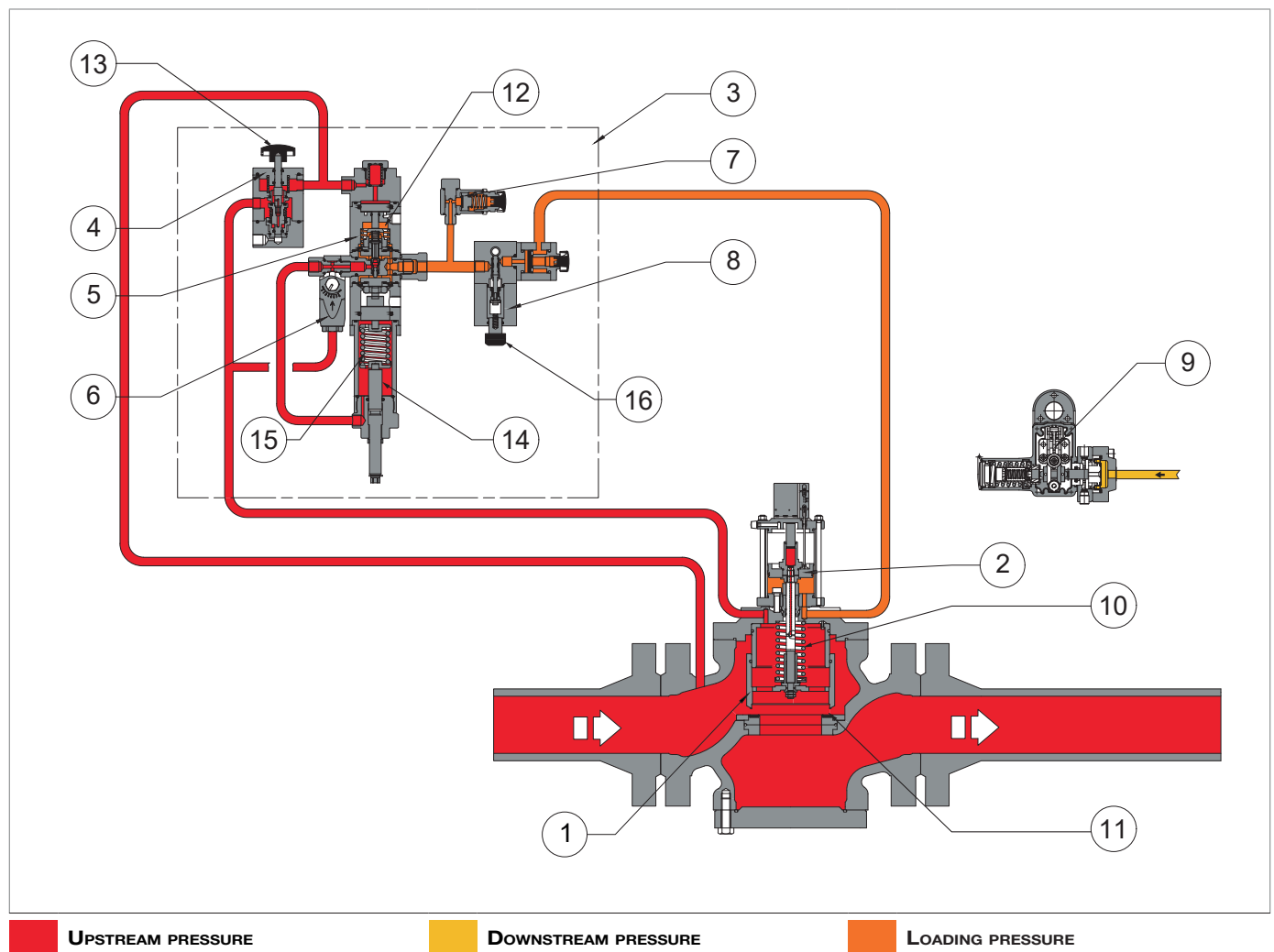

Fig. 4.1. General description HBC 975

The LINE OFF 2.0 device (3) consists of:

Pos.	Description
4	HP2/2: filtering device of the gas supplying the control circuit; it also acts as a bypass necessary for resetting the built-in slam-shut valve HB/97.
5	R44/SS: pressure regulator necessary to decrease the upstream pressure of the equipment to the loading pressure of the HB/97 built-in slam-shut valve's cylinder.
6	AR100: flow lamination valve to adjust the pressure loading speed in the pneumatic circuit and to filter the gas entering the R44/SS regulator (6). <div style="border: 1px solid black; padding: 5px; margin-top: 10px;"> <p><b>! NOTE!</b>  <b>The unloading speed is regulated by a screw (minimum value 1, maximum value 8).</b></p> </div>
7	VS/FI: safety valve used to: <ul style="list-style-type: none"> <li>• discharge any overpressure generated by malfunction of the R44/SS pressure regulator into the atmosphere;</li> <li>• protect the entire circuit downstream of the R44/SS pressure regulator.</li> </ul>
8	Valve 3/2: this device is used to pressurise and depressurise the cylinder of the HB/97 slam-shut valve.
9	Control pressure switch: through the head of the control pressure switch connected downstream, it allows the HB/97 built-in slam-shut valve to trip due to decreases or increases in downstream pressure.

Tab. 4.14.

The HBC 975 slam-shut valve can be operated:

- when the set point is exceeded;
- manually through a button on the pressure gauge;
- remotely.

The main features of the HBC 975 slam-shut valve are:

- balanced valve plug;
- self-powered indirect pneumatic drive;
- local closing button;
- triggering due to downstream pressure increase and/or decrease;
- precision (AG):
  - » 1 on the tripping value for maximum pressure;
  - » 5 on the triggering value for minimum pressure;
- built-in bypass;
- manual resetting only

## 4.2 - OPERATION

At no pressure, the valve plug (1) is kept in the closed position by the spring (10) and rests on the reinforced gasket (11).

The upstream pressure ( $U_p$ ) reaches the HP2/2 (4) and the upper head (12) of the R44/SS regulator (6) to prevent inappropriate resetting of the valve. By acting on the bypass activation button (13), the gas under pressure is filtered and feeds the AR100 valve (5), which in turn supplies:

- the chamber of the adjustment spring (14);
- the upstream of the R44/SS regulator (6), calibrated at a pressure of 4.5 bar to overcome the force of the closing spring (15) of the main valve.

Pressing the reset lever (16) acts on the pressure switch coupling system (9), so as to allow, through the 3/2 valve (8):

- the actuator (2) of the slam-shut valve to be pressurised by the R44/SS regulator (6);
- the plug (1) to open.

In the event that the slam-shut valve is required to trip, the pressure switch coupling system acts on the 3/2 valve to:

- discharge the pressure from the actuator (2) into the atmosphere through the 3/2 valve (8);
- allow the spring (10) to bring the plug (1) to the closing position.

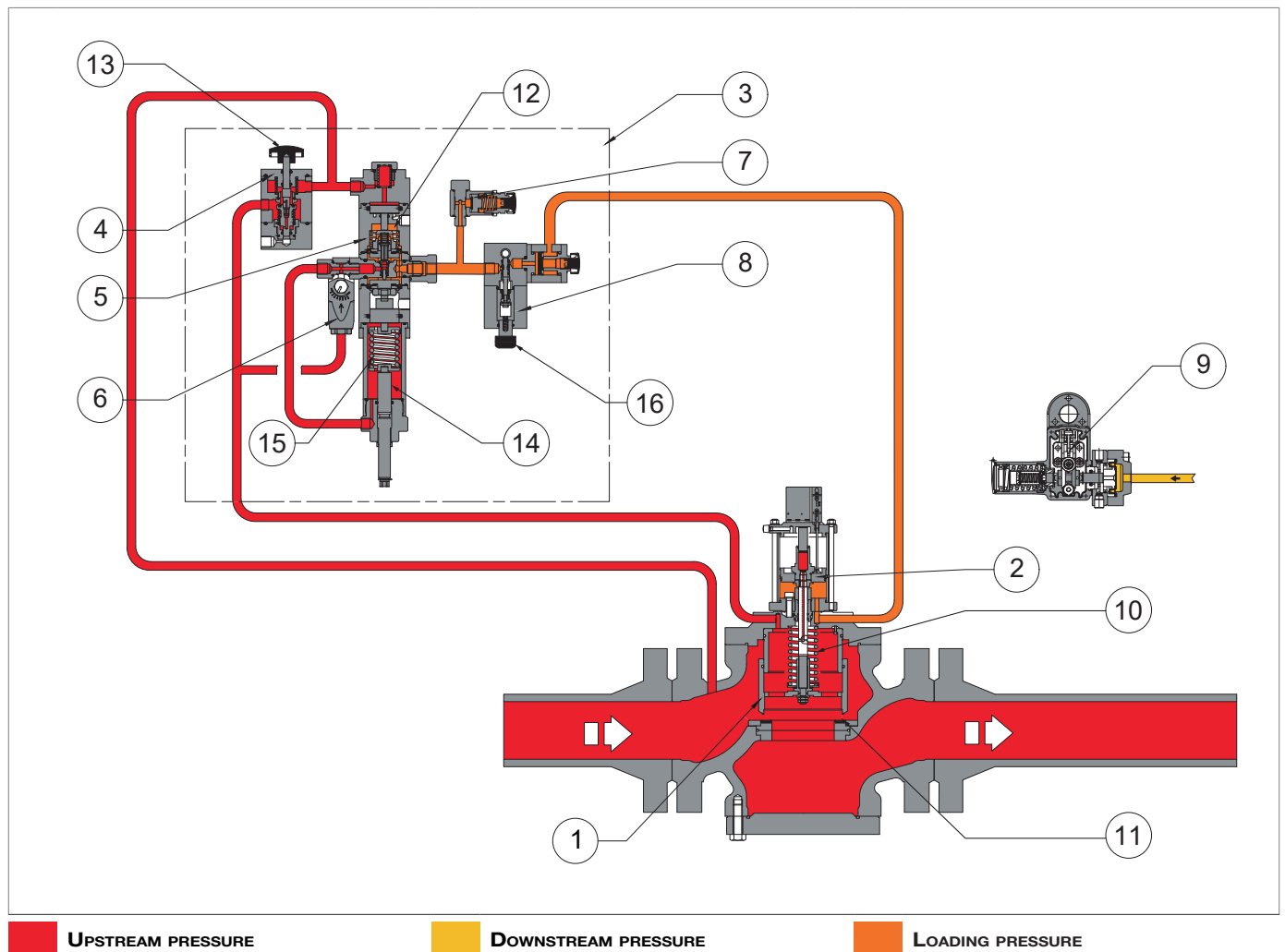

Fig. 4.2. Operation HBC 975

## 4.3 - INTENDED USE

### 4.3.1 - ENVISAGED USE

The equipment in question is intended for:

Operation	Permitted	Not permitted	Work environment
<b>Pressure value monitoring:</b>	Gaseous and non-corrosive fluids that have been filtered beforehand.	<ul style="list-style-type: none"> <li>Liquids.</li> <li>Any product other than those permitted.</li> </ul>	Installations for the transport and distribution of natural gas to supply networks for: <ul style="list-style-type: none"> <li>civil use;</li> <li>industrial use.</li> </ul>

Tab. 4.15.

It was designed to be used exclusively within the limits specified on the nameplate and according to the instructions and limits of use referred to in this manual.

Safe work parameters are:

- use within the limits stated on the nameplate and in this manual;
- compliance with the user manual procedures;
- routine maintenance to be carried out when and how recommended;
- special maintenance to be carried out if required;
- do not tamper with and/or bypass the safety devices.

### 4.3.2 - REASONABLY FORESEEABLE MISUSE

Incorrect and reasonably foreseeable use means the use of the equipment in a way not foreseen in the phase but which can derive from easily predictable human behaviour:

- corrosive fluids;
- fluids not properly treated upstream;
- liquids;
- instinctive reaction of an operator in the event of a malfunction, accident or breakdown while using the equipment;
- behaviour resulting from pressure to keep the equipment running under all circumstances;
- behaviour resulting from carelessness;
- behaviour resulting from the use of the equipment by unauthorised and unsuitable people;
- using the equipment in a manner other than that referred to under "Intended use".

Any use of the equipment other than the intended use must be previously approved in writing by PIETRO FIORENTINI S.p.A. If no written approval is provided, use shall be considered improper.

In the event of "improper use", PIETRO FIORENTINI S.p.A. shall not be held liable for any damage caused to people or property, and any type of warranty on the equipment shall be deemed void.

### 4.3.3 - TYPES OF FLUIDS

The equipment works with combustible gases used:

- in pressure control stations according to EN 12186 or EN 12279;
- in transmission and distribution networks;
- in commercial and industrial plants (after checking by contacting the Manufacturer).

#### **NOTE!**

**In addition, the equipment may be used with inert gases, subject to verification by contacting the manufacturer.**

#### 4.4 - TECHNICAL FEATURES/PERFORMANCE

Slam-shut valve HBC 975 is suitable for medium and high pressure.

HBC 975 is a “top entry” valve, therefore it allows easy maintenance without removing it from the line.

It is also equipped with a button for local closing.

The main specifications of this equipment are:

Technical features	
<b>Maximum allowable pressure</b>	Up to 100 bar
<b>Inlet gas temperature range</b>	-10 °C + 60 °C (class 1) -20 °C + 60 °C (class 2)
<b>Ambient temperature range</b>	-20 °C + 60 °C
<b>Inlet pressure range (bpu)</b>	1 - 100 bar
<b>Accuracy class (AG)</b>	up to 1
<b>Max. pressure tripping range (Wdso)</b>	OPSO 0.2 - 90 bar
<b>Min. pressure tripping range (Wdsu)</b>	UPSO 0.2 - 90 bar

Tab. 4.16.

Cg, Kg and K1 coefficients					
<b>Nominal diameter [mm]</b>	100	150	200	250	300
<b>Size [inches]</b>	4"	6"	8"	10"	12"
<b>Coefficient Cg</b>	8000	16607	25933	36525	55000
<b>Kg coefficient</b>	8416	17471	27282	38425	57860
<b>Coefficient K1</b>	106.78	106.78	106.78	106.78	106.78

Tab. 4.17.





#### 4.4.1 - SLAM-SHUT VALVE PRESSURE SWITCHES

The pressure switch is a control device consisting of:

Pos.	Description
1	Control element. <b>NOTE!</b> <b>The control element can be a diaphragm or a piston.</b>
2	Stem.
3-4	Adjustment feeler gauges.
5	Spring for maximum pressure tripping.
6	Spring for minimum pressure tripping.
7	UPSO minimum spring adjustment ring nut (6).
8	OPSO maximum pressure spring adjustment ring nut (5).
10	Release button.

Tab. 4.18.

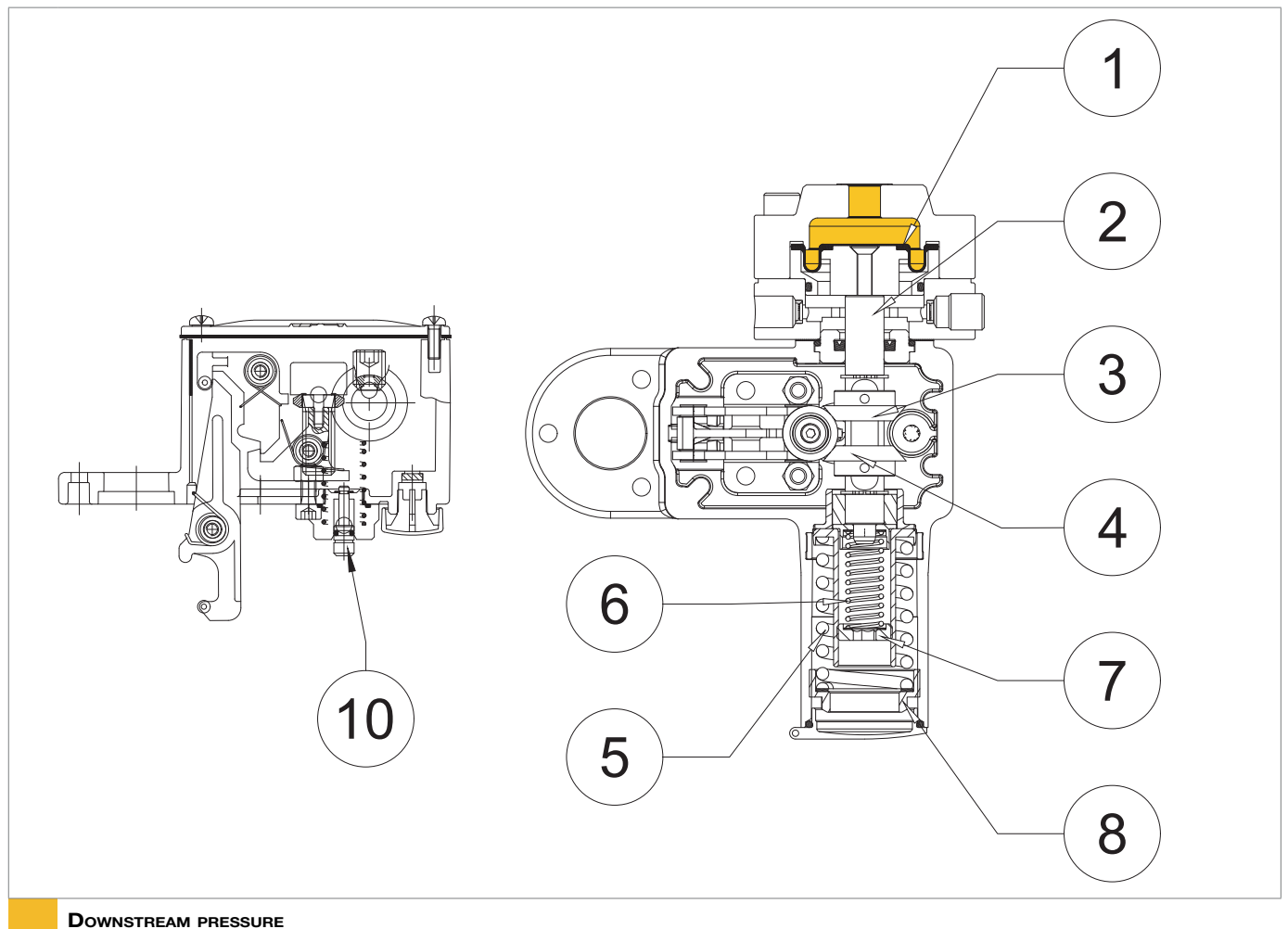

**DOWNSTREAM PRESSURE**

Fig. 4.3. Slam-shut valve pressure switch

Table 4.19 lists the models of the pressure switches available for this valve:

<b>Model pressure switch</b>	<b>Min [bar]</b>	<b>Max [bar]</b>
<b>102M</b>	0.2 - 2.8	0.2 - 5.5
<b>102MH</b>	2.2 - 5.5	0.2 - 5.5
<b>103M</b>	0.2 - 8	2 - 22
<b>103MH</b>	8 - 19	2 - 22
<b>104M</b>	1.6 - 18	15 - 45
<b>104MH</b>	18 - 41	15 - 45
<b>105M</b>	3 - 44	30 - 90
<b>105MH</b>	44 - 90	30 - 90

*Tab. 4.19.*



## 5 - TRANSPORT AND HANDLING

### 5.1 - SPECIFIC WARNINGS FOR TRANSPORT AND HANDLING

**NOTE!**

Transport and handling must be carried out by personnel:

- qualified (specially trained);
- who are familiar with accident prevention and workplace safety regulations;
- authorised to use lifting equipment;
- in line with the regulations and provisions in force in the country of destination of the equipment.

#### Transport with forklift or crane

<b>Operator qualification</b>	Person in charge of transport, handling, unloading and placing on site
<b>PPE required</b>	 <p><b>WARNING!</b></p> <p>The PPE listed in this table is related to the risk associated with the equipment. For the PPE required to protect against risks associated with the workplace, installation or operating conditions, please refer to:</p> <ul style="list-style-type: none"> <li>• the regulations in force in the country of installation;</li> <li>• <u>any information provided by the Safety Manager at the installation facility.</u></li> </ul>
<b>Lifting equipment</b>	Hoist crane, forklift truck or other suitable equipment.
<b>Weights and dimensions of the equipment</b>	For dimensions and weights, refer to paragraph 5.2 "Physical characteristics of the equipment".

Tab. 5.20.

### 5.1.1 - PACKAGING AND FASTENERS USED FOR TRANSPORT

The transport packaging is designed and manufactured to avoid damage during normal transport, storage and handling. The equipment and spare parts must be kept in their packaging until they are installed.



Upon receiving the equipment:

- make sure that no part has been damaged during transport and/or handling;
- immediately report any damage found to PIETRO FIORENTINI S.p.A..

**! NOTE!**

**PIETRO FIORENTINI S.p.A. shall not be liable for any damage to people or property caused by accidents due to failure to comply with the instructions provided in this manual.**

Table 5.21 shows the types of packaging used:

Ref.	Type of packaging	Image
A	Cardboard box	
B	Wooden box	
C	Pallet	

Tab. 5.21.

## 5.2 - PHYSICAL CHARACTERISTICS OF THE EQUIPMENT

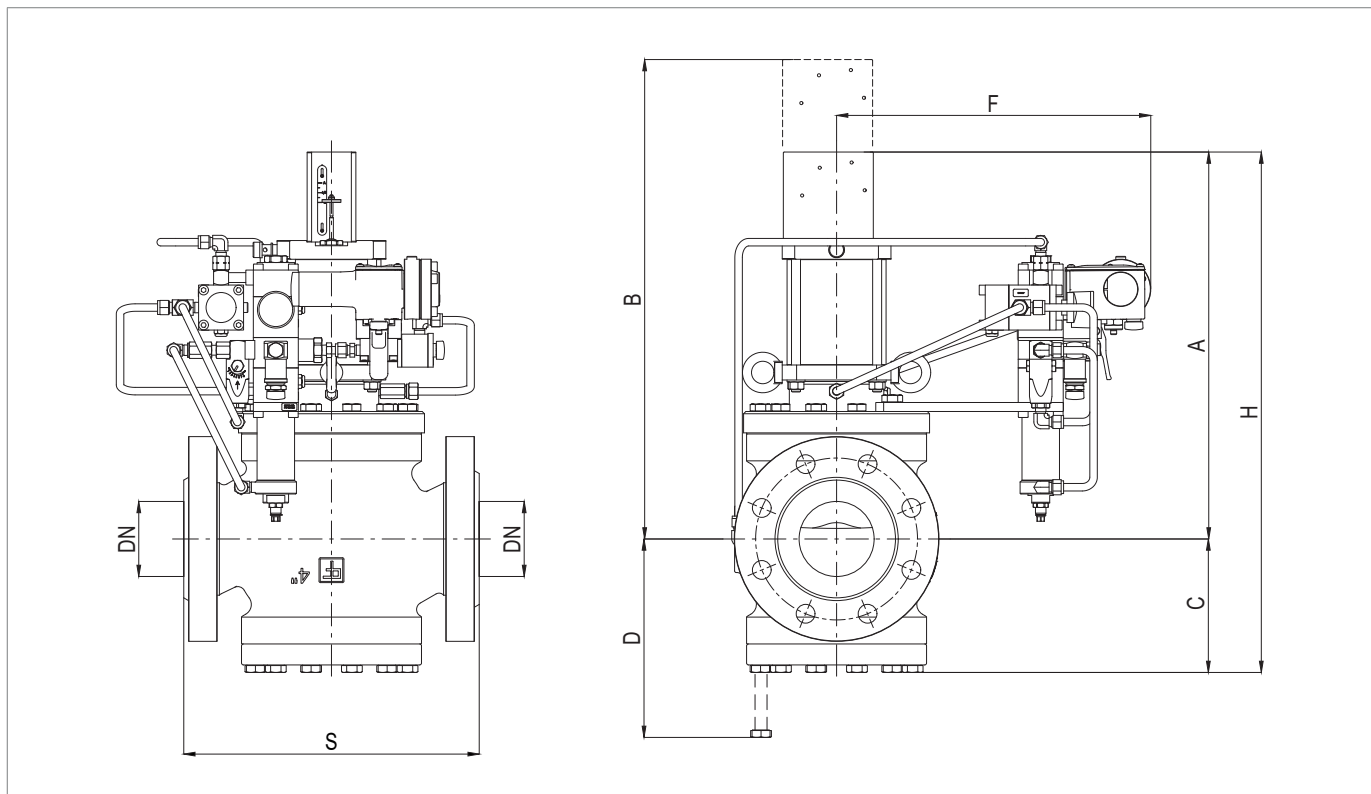

Fig. 5.4. HBC 975 physical characteristics

HBC 975 overall dimensions					
Nominal diameter [mm]	100	150	200	250	300
Size [inches]	4"	6"	8"	10"	12"
<b>S - Class 150/PN 16</b>	352	451	543	673	737
<b>S - Class 300</b>	368	473	568	708	775
<b>S - Class 600</b>	394	508	609	752	819
<b>A</b>	518	645	687	796	940
<b>B</b>	650	835	900	1060	1220
<b>C</b>	180	225	265	340	372
<b>D</b>	205	275	320	440	480
<b>F</b>	358	410	445	510	530
<b>H</b>	700	870	952	1136	1312

Tab. 5.22.

Weight [kgf]					
<b>Class 150/PN 16</b>	104	233	305	600	1125
<b>Class 300</b>	120	239	349	650	1200
<b>Class 600</b>	131	256	375	700	1300

Tab. 5.23.

### 5.3 - ANCHORING AND LIFTING METHOD

 **HAZARD!**

**Before moving the equipment, make sure that the capacity of the lifting equipment is suitable for the load.**

 **WARNING!**

Unloading, transport and handling activities must be carried out by operators qualified and specially trained:

- on accident prevention rules;
- on maximum safety in the workplace;
- on the use of lifting equipment.

 **ATTENTION!**

Before moving the equipment:

- remove any movable or hanging component or firmly secure it to the load;
- protect fragile equipment;
- check that the load is stable.



### 5.3.1 - FORKLIFT HANDLING METHOD

**HAZARD!**

**Prohibitions:**

- Do not transit under suspended loads;
- Do not move the load over the personnel operating in the site/plant area.

**WARNING!**



**The following is not allowed on forklifts:**

- carrying passengers;
- lifting people.

**NOTE!**

**Packaging must always be handled in a vertical position**

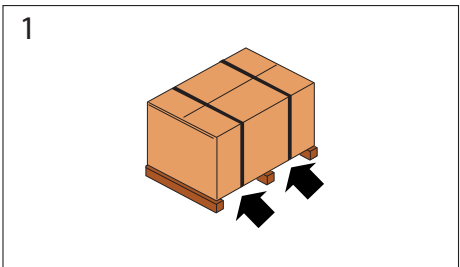
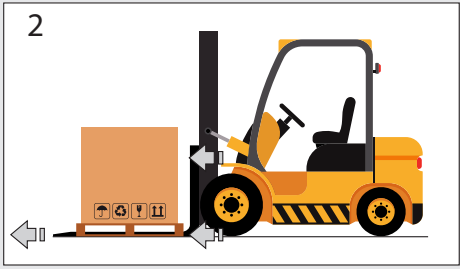
Proceed as follows:

Step	Action	Image
1	Place the forks of the forklift under the load surface.	<p>1</p> 
2	Make sure that the forks extend from the front of the load (by at least 5 cm), far enough to eliminate any risk of the transported load from tipping.	<p>2</p> 
3	<p>Raise the forks until they are touching the load.</p> <div style="border: 1px solid blue; padding: 5px; margin-top: 10px;"> <p><b>NOTE!</b> Fasten the load to the forks with clamps or similar devices if required.</p> </div>	<p>3</p> 
4	Slowly lift the load by a few dozen centimetres and check its stability, making sure that the centre of gravity of the load is positioned at the centre of the lifting forks.	<p>4</p> 

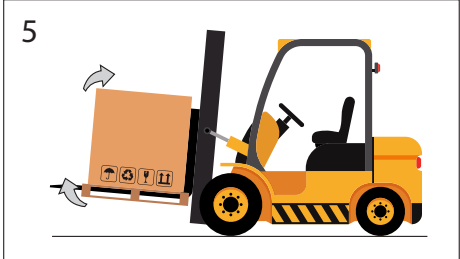
Step	Action	Image
5	Tilt the mast backwards (towards the driver's seat) to help the over-turning moment and to ensure greater load stability during transport.	
6	Adjust transport speed according to the type of floor and load, avoiding sudden manoeuvres. <b>⚠ WARNING!</b> <b>If:</b> <ul style="list-style-type: none"> <li>• <b>obstacles along the path;</b></li> <li>• <b>particular operating situations;</b></li> </ul> <b>do not allow the operator a perfect view, the assistance of a ground operator is required, placed outside the range of action of the lifting means, with the task of carrying out reports.</b>	-
7	Place the load in the chosen installation area.	-

*Tab. 5.24.*

### 5.3.2 - CRANE HANDLING METHOD

#### WARNING!

It is mandatory to use CE marked chains, ropes and eyebolts or marked with conformity marks in accordance with the regulations in force in the place of installation. Do not use chains connected to each other by bolts.

Always check that:

- the safety catch of the hook returns to the initial position;
- the ropes are in excellent condition and have an adequate section.



Prohibitions:

- do not drag the load on the ground;
- do not operate near power lines;
- do not stand within the range of action of the crane.

#### NOTE!

Packaging must be always handled in a vertical position.

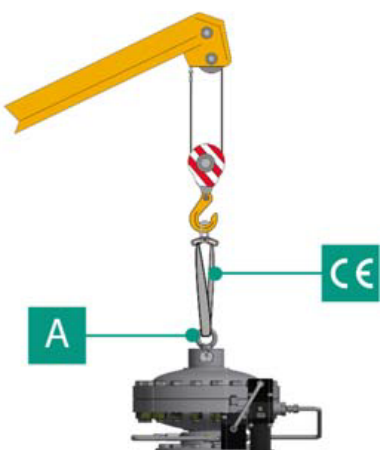
The equipment must be handled using the lifting points provided on the equipment itself. To carry out the transport correctly, follow the procedure below:

Step	Action	Image
1	Attach the lifting rope or chain to the appropriate supports (A).  <b>WARNING!</b> <b>The lifting point is sized for lifting only the equipment, and not other parts of the system connected to it.</b>	
2	Slightly lift the load making sure the ropes or chains are secure.  <b>NOTE!</b> <b>Check whether the load is properly balanced.</b>	
3	Handle the load avoiding sudden movements.	
4	Place the load in the chosen installation area.	

Tab. 5.25.

## 5.4 - PACKAGING REMOVAL

Packaging removal	
Operator qualification	<ul style="list-style-type: none"> <li>Person in charge of transport, handling, unloading and placing on site;</li> <li>Installer.</li> </ul>
PPE required	 <p><b>WARNING!</b></p> <p>The PPE listed in this table is related to the risk associated with the equipment. For the PPE necessary to protect against risks associated with the workplace or operating conditions, please refer to:</p> <ul style="list-style-type: none"> <li>the regulations in force in the country of installation;</li> <li>any information provided by the Safety Manager at the installation facility.</li> </ul>

Tab. 5.26.

To unpack the equipment, proceed as follows:

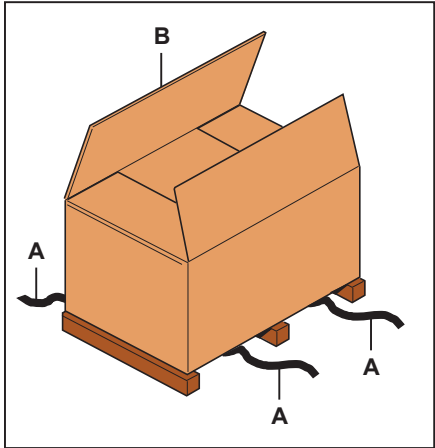
Step	Action	Image
1	Remove the straps (A).	
2	Remove the packaging cardboard (B).	
3	Remove the fasteners that secure the equipment to the base (if any).	
4	<p>Move the equipment from the base to the place intended for it.</p> <p><b>NOTE!</b> Have at least 2 operators manually move the equipment, if required due to its dimensions/weight.</p>	

Tab. 5.27.

### **NOTE!**

After removing all packaging materials, check for any anomalies.

If there are anomalies:

- do not install the equipment;
- contact PIETRO FIORENTINI S.p.A. and specify the details provided on the equipment nameplate.

### 5.4.1 - PACKAGING DISPOSAL

### **NOTE!**

Sort the various materials making up the packaging and dispose of them in compliance with the regulations in force in the country of installation.

## 5.5 - STORAGE AND ENVIRONMENTAL CONDITIONS

If the equipment is to be stored for an extended period, the minimum environmental conditions for the intended storage are provided. Only by complying with these requirements can the declared performance be guaranteed:

Conditions	Data
Maximum storage period	Maximum 3 years. <div style="border: 1px solid black; padding: 5px;">  <b>NOTE!</b>  <b>For installations in subsequent periods, see paragraph 5.5.1 “Pre-installation warnings after prolonged storage”.</b> </div>
Temperature	Not above 40°C
Humidity	Not above 70%
Radiation	Away from radiation sources according to UNI ISO 2230:2009

Tab. 5.28.

### 5.5.1 - PRE-INSTALLATION WARNINGS AFTER PROLONGED STORAGE

For installations that have been stored for longer than 3 years, the condition of all rubber parts must be checked and, if found to be damaged, they must be replaced in order to ensure the correct functioning of the equipment.

To replace the rubber parts of the equipment, please refer to chapter 9 “Maintenance and functional checks”.

 <b>NOTE!</b> <b>PIETRO FIORENTINI S.p.A. recommends checking the condition of rubber parts in case of downtime or storage of more than 3 years.</b>
--



## 6 - INSTALLATION

### 6.1 - INSTALLATION PRE-REQUISITES

#### 6.1.1 - ENVIRONMENTAL CONDITIONS ALLOWED

The installation site must be suitable for the safe use of the equipment.

The installation area of the equipment must be properly lit to ensure that the operator has good view when working on the equipment.

#### NOTE!

The equipment must operate in places that are properly lit by artificial lighting that is suitable for the protection of the operator (in compliance with UNI EN 12464-1:2011 and UNI EN 12464-2:2014). If maintenance work is to be performed in areas and/or parts that are poorly lit, it is mandatory to:

- use all the light sources of the installation plant;
- equip themselves with a portable lighting system or connected to the power supply network.

#### ATTENTION!

To safely use the equipment, check the details on the nameplates of the regulator and/or its accessories, if any.

## 6.1.2 - CHECKS BEFORE INSTALLATION

With reference to its **PS admissible pressure**, the equipment does not require any further safety device upstream to protect against any overpressure when, for the upstream reduction station, the maximum incidental downstream pressure is:

$$\text{MIPd} \leq 1.1 \text{ PS}$$

**MIPd** = maximum incidental downstream pressure value (for further information, see UNI EN 12186:2014).

### **ATTENTION!**

**If the installation of the equipment requires the field application of compression fittings, these must be installed in accordance with the instructions of the Manufacturer of the fittings themselves.**



**The choice of fittings must be compatible with:**

- **the use specified for the equipment;**
- **the plant specifications when required.**

Before installation, it must be ensured that:

- the expected dimensions of the installation site are compatible with the equipment size;
- there is a space around the equipment that facilitates maintenance operations for employees;
- the upstream and downstream pipes are at the same level and can bear the weight of the equipment;
- the inlet and outlet connections of the pipe are parallel;
- the inlet and outlet connections of the equipment are clean and have not been damaged;
- the inside of the upstream pipe is clean and free of processing residues such as welding slag, sand, paint residues, water, etc...

### Installation

<b>Operator qualification</b>	Installer
<b>PPE required</b>	 <p><b> WARNING!</b></p> <p><b>The PPE listed in this table is related to the risk associated with the equipment. For the PPE required to protect against risks associated with the workplace, installation or operating conditions, please refer to:</b></p> <ul style="list-style-type: none"> <li>• <b>the regulations in force in the country of installation;</b></li> <li>• <b>any information provided by the Safety Manager at the installation facility.</b></li> </ul>
<b>Equipment required</b>	Refer to chapter 7 "Equipment for commissioning/maintenance".

Tab. 6.29.



## 6.2 - SPECIFIC SAFETY INSTRUCTIONS FOR THE INSTALLATION STEP

 **WARNING!**

Before proceeding with installation, make sure that the upstream and downstream valves installed on the line are closed.

 **WARNING!**

The installation may also take place in areas where there is a risk of explosion and this implies that all necessary prevention and protection measures must be taken.

For these measures, please refer to the regulations in force at the place of installation.

### 6.3 - GENERAL INFORMATION ON CONNECTIONS

The device must be installed in the line, with the arrow on its body pointing to the gas flow direction.  
The online installation must include:

Pos.	Description
1	One <b>shut-off valve upstream</b> of the equipment
2	Two <b>vent valves</b> (2) located one upstream and one downstream of the equipment
3	Two <b>pressure gauges</b> (2), one upstream and another downstream of the equipment
4	One <b>slam-shut valve</b>
5	One <b>shut-off valve downstream</b> of the equipment

Tab. 6.30.

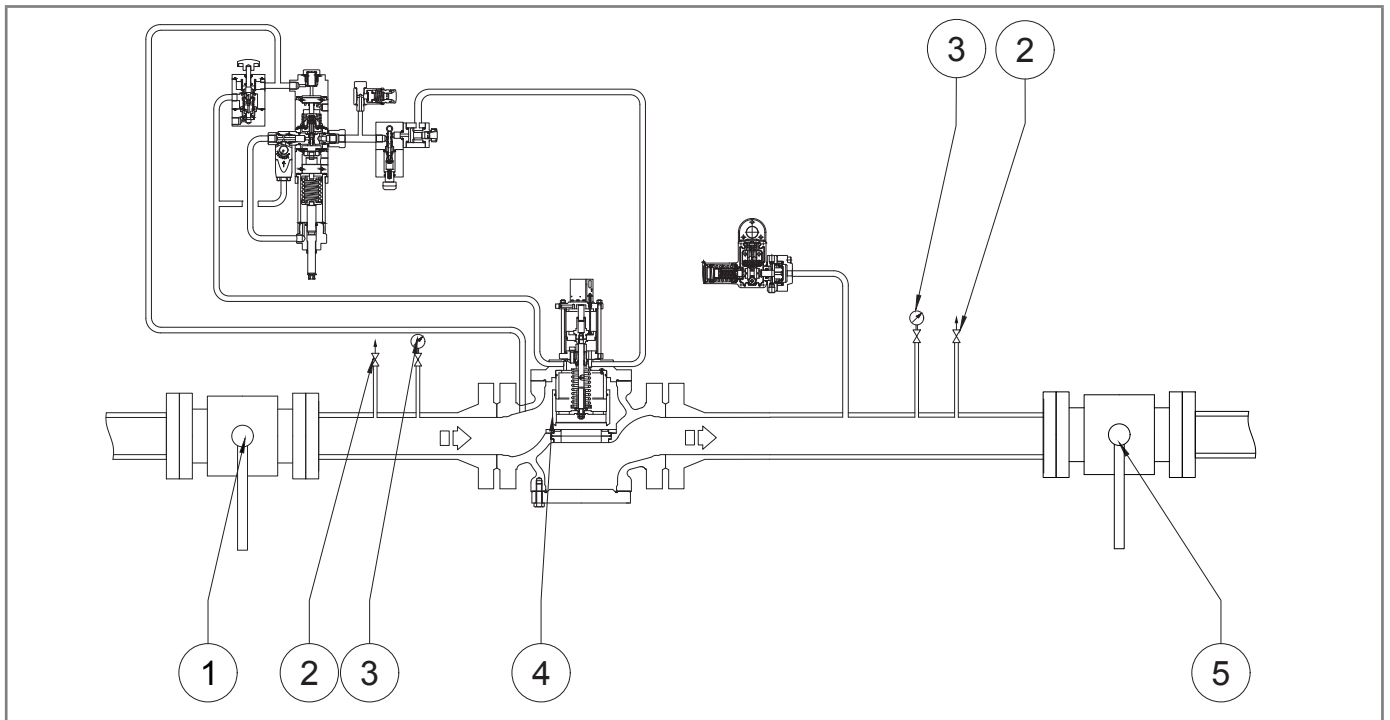

Fig. 6.5. In-line installation

#### NOTE!

When used in gas pressure reduction stations, the device must be installed at least according to the requirements of standards UNI EN 12186:2014 or UNI EN 12279:2007.

Equipment vents must be ducted in accordance with UNI EN 12186:2014 or UNI EN 12279:2007 or the standards in force at the place of installation of the equipment.

## 6.4 - EQUIPMENT INSTALLATION POSITIONS

Figures 6.6 and 6.7 show the permitted arrangements:

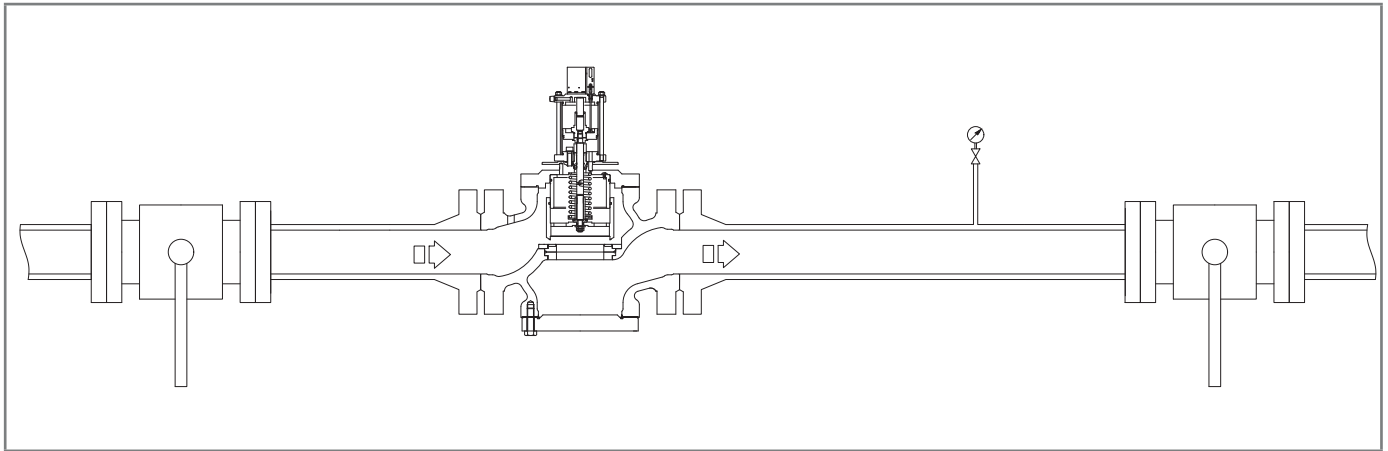

*Fig. 6.6. Standard position*

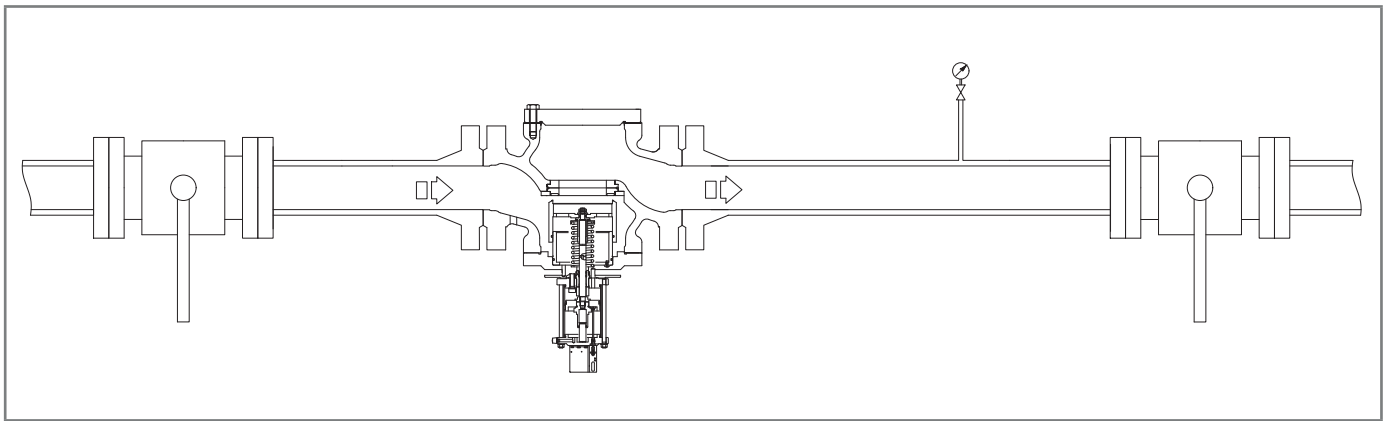

*Fig. 6.7. Inverted position*

## 6.5 - INSTALLATION PROCEDURES

### 6.5.1 - IN-LINE EQUIPMENT INSTALLATION PROCEDURE

To install the equipment in line and in a square pattern, proceed as follows:

Step	Action
1	Place the equipment in the section of the line designated for it.
2	Place the gaskets between the line flange and the equipment flange.
3	Insert the bolts into the appropriate holes of the connecting flanges.
4	Screw the bolts following the technical rules for tightening flanges.

Tab. 6.31.

### 6.5.2 - CONNECTION OF THE SENSING LINES TO THE DOWNSTREAM PIPING

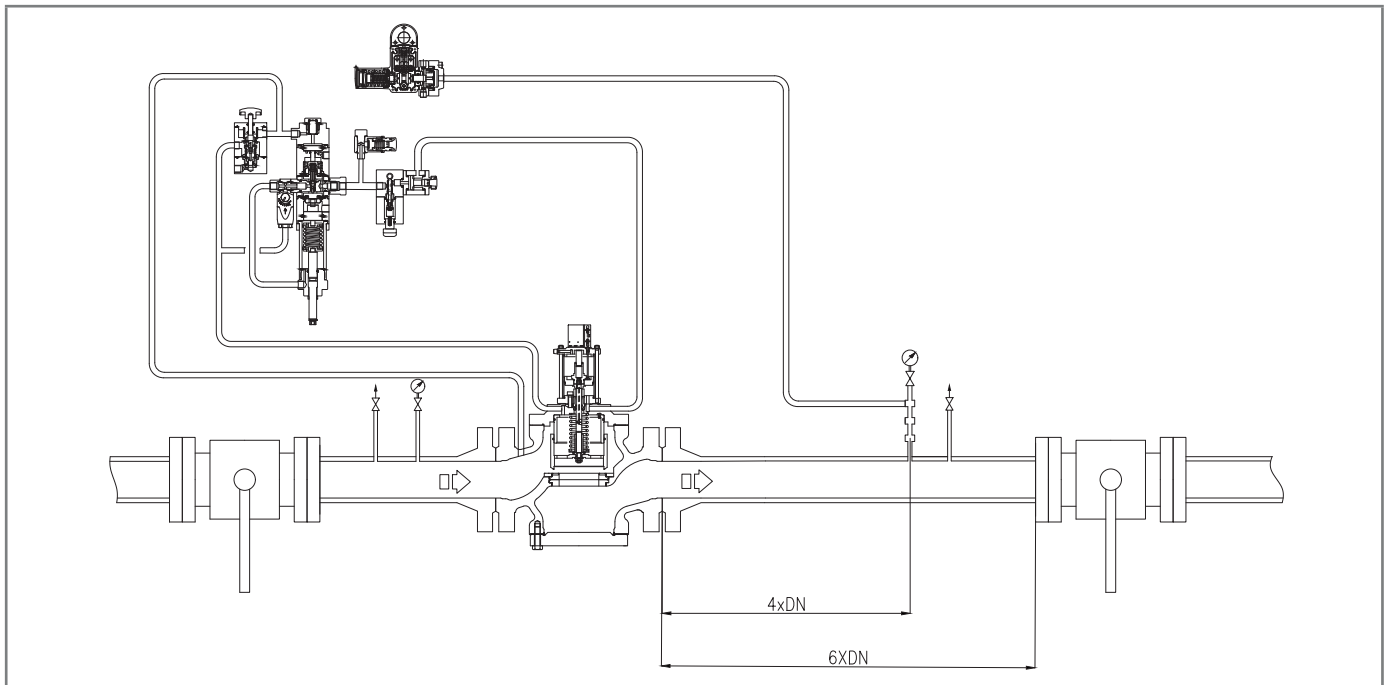

Fig. 6.8. Welded pipe connections

To obtain correct operation, it is essential that:

- the downstream shut-off valve is placed at a distance of at least 6 times the rated diameter of the pipe downstream of the equipment;
- the downstream sensing lines are placed on a straight section of pipe (with uniform diameter) having a length equal to at least 4 times the rated diameter of the pipe itself.
- the velocity of the pressurised fluid at the sampling point does not exceed the following values:  
 $V_{max} = 30 \text{ m/s}$  for  $P_a > 5 \text{ bar}$   
 $V_{max} = 25 \text{ m/s}$  for  $P_a < 5 \text{ bar}$

To calculate the flow rate, use the following formula:

$$V = 345,92 \times \frac{Q}{DN^2} \times \frac{1 - 0,002 \times Pd}{1 + Pd}$$

**V** = gas velocity in m/sec

**Q** = gas flow rate Stm<sup>3</sup>/h

**DN** = nominal diameter of the regulator in mm

**Pd** = regulator outlet pressure in barg

**NOTE!**

All on-site pneumatic connections must have pipes with a minimum internal diameter of 8 mm.

**ATTENTION!**

If a regulator is installed downstream of the slam-shut valve, refer to the regulator manual to connect the sensing lines.

To prevent the pneumatic connections of the sensing lines from collecting impurities and condensation, it is necessary that:

- the pneumatic connection couplings are always welded on the upper part or at maximum 90 degrees on the axis of the pipe (refer to fig. 6.9);
- the hole in the piping has no burrs or internal protrusions;
- the slope of the pneumatic connection is always 5-10% towards the downstream pipe connection.

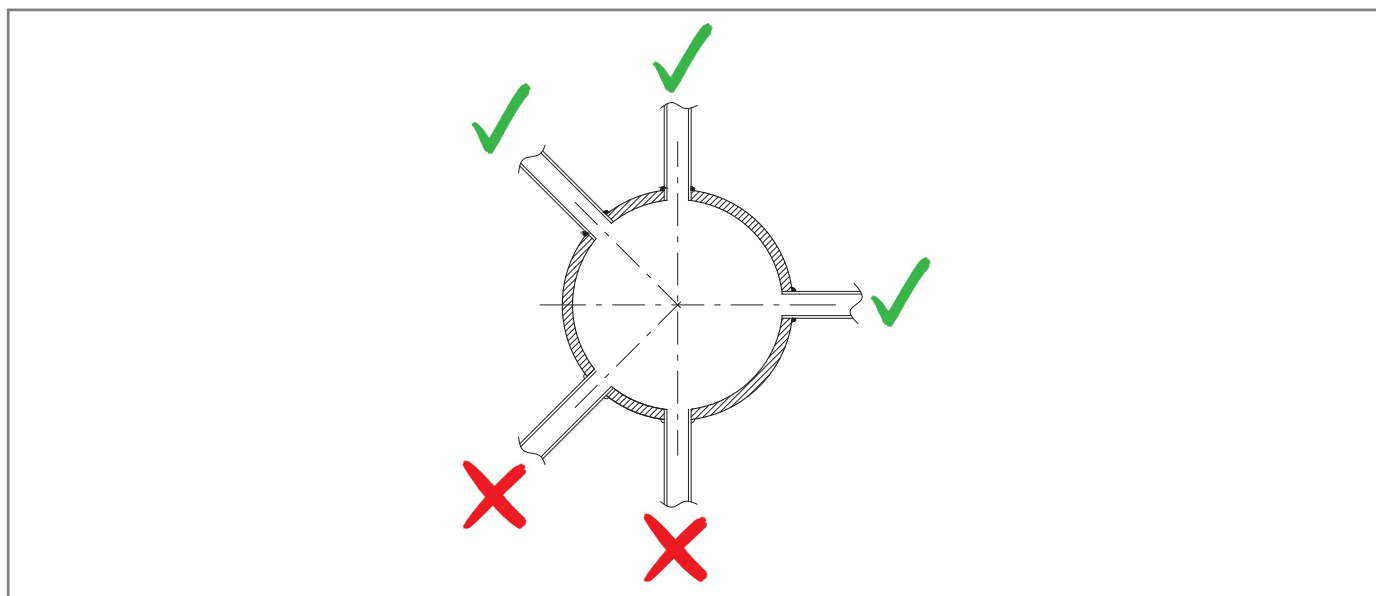

Fig. 6.9. Welded connections of the pneumatic connection

If there is a multiple sensing line (see fig. 6.10), provide equipment connections as shown below:

- 3 and 4 to the pilot sensing lines if any;
- 5 and 6 to the sensing lines of the LINE OFF 2.0 pressure switch.

**! NOTE!**

**If there is a multiple sensing line, it is not recommended to place shut-off valves on sensing lines. In any case, follow the regulations in force in the place of installation and use of the equipment.**

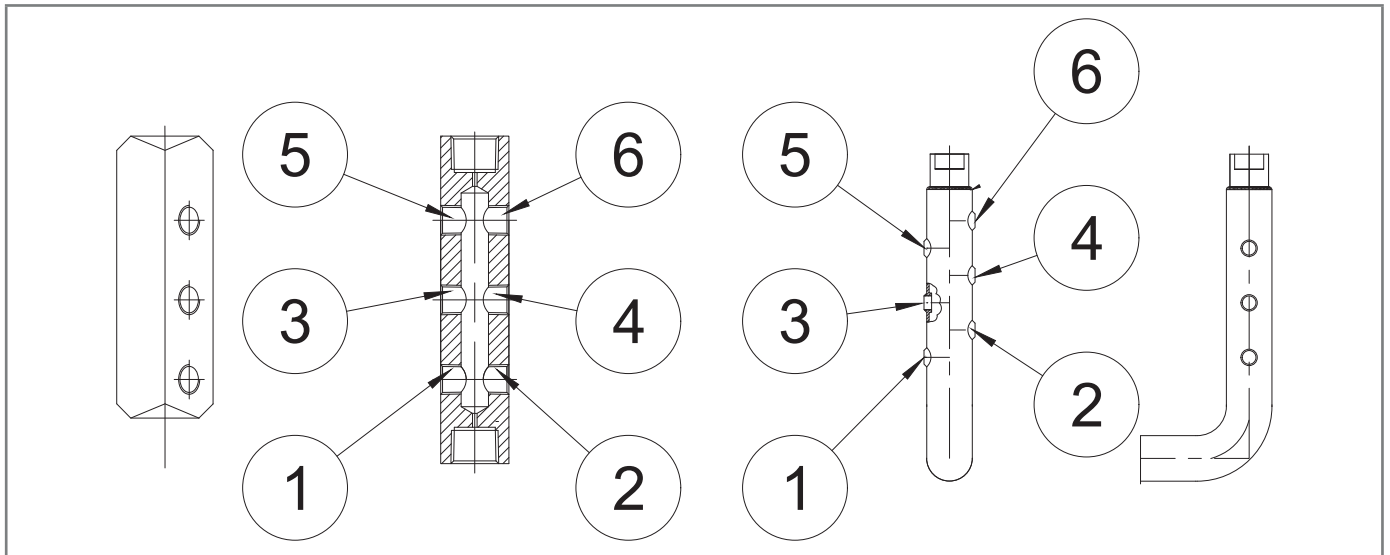

Fig. 6.10. Equipment connections

## 6.6 - POST-INSTALLATION AND PRE-COMMISSIONING CHECKS

Before commissioning, it must be ensured that all connections are:

- properly secured/tightened to prevent any leakage during commissioning;
- connected correctly.







## 7 - COMMISSIONING AND MAINTENANCE EQUIPMENT





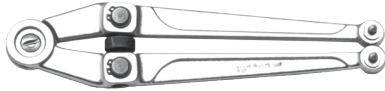

### 7.1 - LIST OF REQUIRED EQUIPMENT

Commissioning/maintenance equipment	
<b>Operator qualification</b>	<ul style="list-style-type: none"> <li>• Mechanical maintenance technician;</li> <li>• Electrical maintenance technician;</li> <li>• Installer;</li> <li>• Name of the user.</li> </ul>
<b>PPE required</b>	<div style="display: flex; align-items: center;">  </div> <div style="background-color: #f4a460; padding: 5px; margin-top: 5px;"> <p><b>⚠ WARNING!</b></p> </div> <p>The PPE listed in this table is related to the risk associated with the equipment. For the PPE required to protect against risks associated with the workplace, installation or operating conditions, please refer to:</p> <ul style="list-style-type: none"> <li>• the regulations in force in the country of installation;</li> <li>• any information provided by the Safety Manager at the installation facility.</li> </ul>

Tab. 7.32.

The types of equipment required for commissioning and maintenance of the equipment are described in table 7.33:

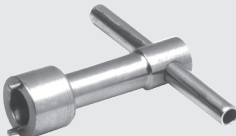
Ref.	Equipment type	Image
A	Combination wrench	
B	Adjustable wrench	
C	Roller compass wrench	
D	Double ended bi-hex tubular socket wrench	
E	Bent male hex key	
F	Male T-handle hex wrench	

Ref.	Equipment type	Image
<b>G</b>	T-handle hex socket wrench	
<b>H</b>	Phillips screwdriver	
<b>I</b>	Slotted screwdriver	
<b>L</b>	O-ring extraction tool	
<b>M</b>	Circlip pliers	
<b>N</b>	Fiorentini special key	
<b>O</b>	Fiorentini special key	
<b>P</b>	Fiorentini special tool	

Tab. 7.33.



## 7.2 - EQUIPMENT NEEDED FOR THE DIFFERENT CONFIGURATIONS

Table 7.35 provides the following details:

Term	Description
<b>K.</b>	Key, with reference to the equipment indicated in tab. 7.33.
<b>Code</b>	Code, referring to the equipment.
<b>DN</b>	Indicates the Nominal Diameter of the reference configuration.
<b>L.</b>	Length, referred to the equipment.
<b>Ref.</b>	Reference to the equipment.
<b>Type</b>	Type (size) or code of the equipment.

Tab. 7.34.

HBC 975					
Equipment		DN			
Ref.	Type	4"	6"	8"	10"
<b>A</b>	K.	7-14-17-19-22-24-27-30-32-41	7-14-17-19-22-24-27-30-32-41	7-14-17-19-22-24-27-32-41	7-14-16-17-19-24-27-32-36-50-57
<b>B</b>	L.	300			
<b>C</b>	Ø	4			
<b>D</b>	K.	9-10-15-17-21-22-24-27	9-10-15-17-21-22-24-27	9-10-15-17-21-22-24-27	17-21-27-30
<b>E</b>	K.	9-10-15-24	9-10-15-24	9-10-15-24	27
<b>F</b>	K.	2-3-4-5-6	2-3-4-5-6	2-3-4-5-6	2-3-4-5-6-17
<b>I</b>	L.	6.5 x 100			
<b>L</b>	Code	7999099			
<b>M</b>	Ø	16-60			
<b>N</b>	Code	7999019			
<b>P</b>	Code	7999097			

Tab. 7.35.



## 8 - COMMISSIONING

### 8.1 - GENERAL WARNINGS

#### 8.1.1 - SAFETY REQUIREMENTS FOR COMMISSIONING

##### HAZARD!

During commissioning the risks associated with any discharges to the atmosphere of flammable or noxious gases must be evaluated.

##### HAZARD!

In case of installation on distribution networks for natural gas, consider the risk associated with explosive mixtures (gas/air) being formed inside the piping, if the line is not subjected to inerting.

##### WARNING!

During commissioning, unauthorised personnel must be removed.  
The no entry area must be marked with signs and/or boundaries.

##### NOTE!

Commissioning must be carried out by authorised and qualified personnel.

The equipment is supplied with the pressure switch / control device already calibrated.



##### NOTE!

It is possible that for various reasons (e.g. vibrations during transport) the calibration of the equipment's accessories may vary, although within the values indicated on the identification plates.

Before commissioning the equipment, it is necessary to check that:

- all shut-off valves (inlet, outlet, any bypass) are closed;
- the gas is at a temperature within the limits specified on the data plate.

#### Commissioning

<b>Operator qualification</b>	<ul style="list-style-type: none"> <li>• Installer;</li> <li>• Name of the user.</li> </ul>
<b>PPE required</b>	 <p> <b>WARNING!</b></p> <p>The PPE listed in this table is related to the risk associated with the equipment. For the PPE required to protect against risks associated with the workplace, installation or operating conditions, please refer to:</p> <ul style="list-style-type: none"> <li>• the regulations in force in the country of installation;</li> <li>• any information provided by the Safety Manager at the installation facility.</li> </ul>
<b>Necessary equipment</b>	Refer to chapter 7 "Equipment for commissioning/maintenance".

Tab. 8.36.

## 8.2 - PRELIMINARY PROCEDURES FOR COMMISSIONING

### HAZARD!

Before commissioning the equipment, it must be ensured that any source of explosion has been eliminated if there is such a danger.

### WARNING!

Before commissioning, you need to make sure that the characteristics of the equipment are suitable for the conditions of use.

### ATTENTION!

To protect the equipment from damage, the following operations must never be carried out:

- pressurisation through a valve located downstream of the equipment;
- depressurisation through a valve located upstream of the equipment.

Commissioning can be carried out using two different procedures:

### Commissioning types

<b>Injection of an inert fluid</b>	Pressurising the equipment by injecting an inert fluid (e.g. nitrogen) to avoid potentially explosive mixtures for services with combustible gases. <div style="background-color: #f4a460; padding: 5px;"><b> WARNING!</b></div> <b>During pressurisation, always check that the equipment has no leaks.</b>
<b>Direct injection</b>	Direct injection of gas into pipes, keeping the gas velocity in the pipes as low as possible (maximum permitted value of 5 m/s).

Tab. 8.37.

### 8.3 - PROPER COMMISSIONING CHECK

	Seal	Procedure
<b>External</b>	Element under pressure	Apply a foaming agent and verify that no internal leaks are visible.
<b>Internal</b>	Element separating two pressure chambers	The pressure in the closed chamber with the lower pressure remains stable for a period of not less than 15 minutes

### 8.4 - CALIBRATION OF ANY ACCESSORIES

The slam-shut valve is normally supplied already set with the required calibration value, but for safety it is advisable to check the calibration according to the procedures illustrated in the following chapters.

**8.5 - PROCEDURE FOR COMMISSIONING THE EQUIPMENT**

**8.5.1 - PROCEDURE FOR CHECKING THE SLAM-SHUT VALVE FOR SEALING**

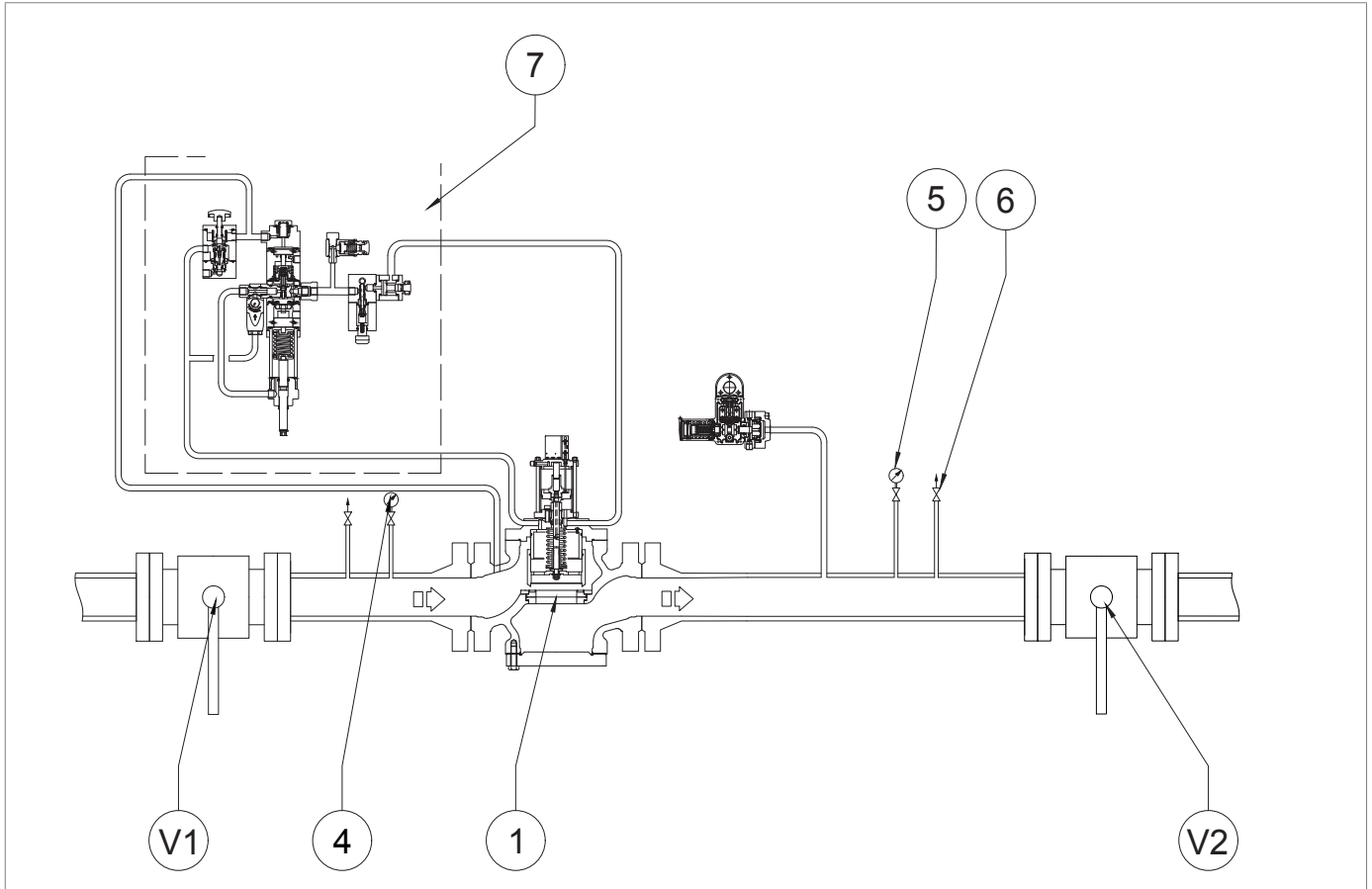

Fig. 8.11. Sealing of the HBC 975 slam-shut valve when closing

Step	Action
1	Check that the slam-shut valve (1) is in the closed position. <b>NOTE!</b> Refer to the indicator rod above the slam-shut valve.
2	Open the vent (6).
3	Drain the downstream section completely.
4	Open the upstream valve (V1). <b>NOTE!</b> Use a foaming substance to check sealing through the vent (6).

Tab. 8.38.



## 8.5.2 - CALIBRATION PROCEDURE FOR PRESSURE SWITCHES MOD. 100 FOR LINE OFF 2.0

### 8.5.2.1 - CALIBRATION PROCEDURE WITHOUT MAIN REGULATOR

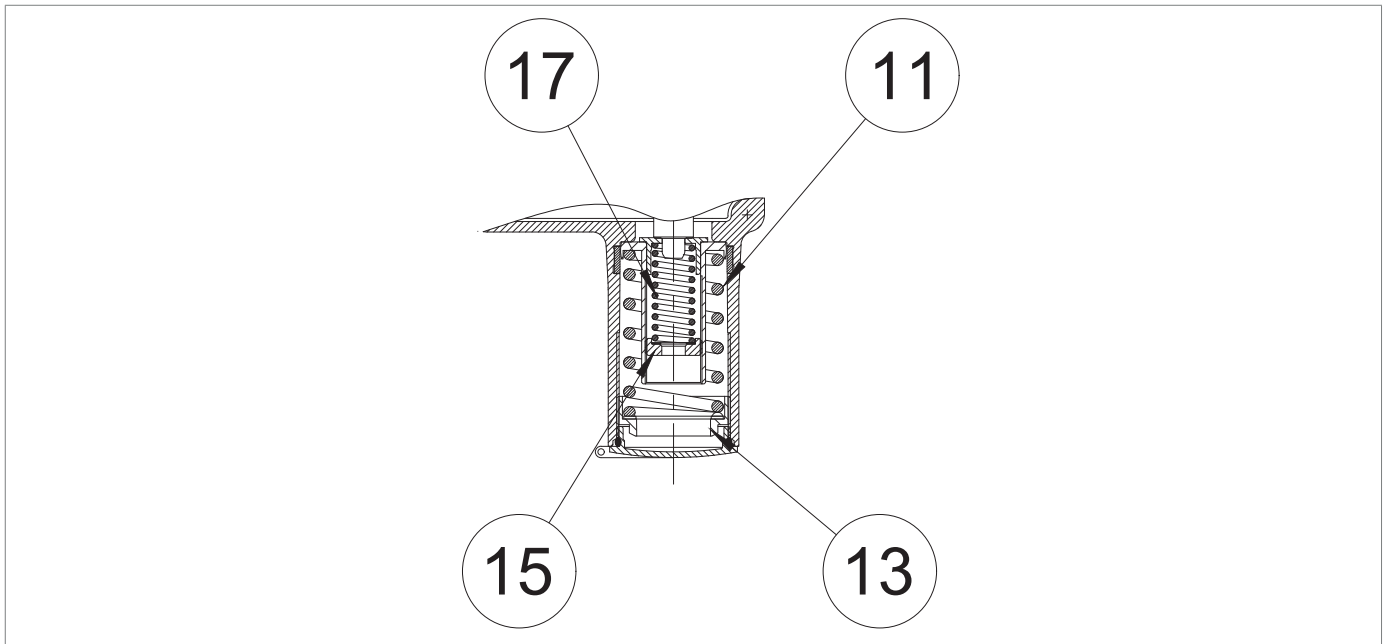

Fig. 8.12. Calibration of pressure switches Mod.100

### SPRING CALIBRATION FOR MAXIMUM PRESSURE TRIP

Step	Action
1	Disconnect the sensing line between pressure switch and line.
2	<p>Increase the pressure in the pressure switch head, using an external pressure source to verify correct calibration.</p> <p><b>NOTE!</b></p> <p><b>Check the pressure by referring to the additional pressure gauge on the external source used for calibration.</b></p> <p><b>If the slam-shut valve:</b></p> <ul style="list-style-type: none"> <li>trips before the expected pressure value: screw in (clockwise) the adjustment ring nut (13) so as to further compress the spring (11);</li> <li>does not trip at the expected pressure value: unscrew (anticlockwise) the adjustment ring nut (13) so as to relieve the spring (11).</li> </ul>
3	Decrease the pressure in the pressure switch head.
4	Trigger the slam-shut device by operating the lever in the 3/2 valve (fig. 4.1, ref. 8).
5	<p>Repeat steps 2-3-4 at least three times.</p> <p><b>NOTE!</b></p> <p><b>The calibration value must comply with the operating limits specified on the plate.</b></p>
6	Disconnect the external pressure source from the pressure switch sensing line.
7	Reconnect the sensing line between pressure switch and line.

Tab. 8.39.



**SPRING CALIBRATION FOR MINIMUM PRESSURE TRIP (IF ANY)**

Step	Action
1	Disconnect the sensing line between pressure switch and line.
2	Use an external pressure source connected to the pressure switch sensing line to inject pressure into the pressure switch head. <b>NOTE!</b> <b>Increase the pressure up to the slam-shut device reset value.</b>
3	Trigger the slam-shut device by operating the lever in the 3/2 valve (fig. 4.1, ref. 8).
4	Release the pressure from the pressure switch up to the tripping value of the slam-shut valve. <b>NOTE!</b> <b>The calibration value must comply with the operating limits specified on the plate.</b>
5	<b>NOTE!</b> <b>Check the pressure by referring to the additional pressure gauge on the external source used for calibration.</b> <b>If the slam-shut valve:</b> <ul style="list-style-type: none"> <li>trips before the expected pressure value: unscrew (anticlockwise) the adjustment ring nut (15) so as to relieve the spring (17);</li> <li>does not trip before the expected pressure value, screw in (clockwise) the adjustment ring nut (15) so as to further compress the spring (17).</li> </ul>
6	Check the minimum pressure spring for proper calibration by repeating steps 2-3-4 at least three times. <b>NOTE!</b> <b>The calibration value must comply with the operating limits specified on the plate.</b>
7	Check the maximum pressure spring for proper calibration by repeating steps 2-3-4 of table 8.39 at least three times. <b>NOTE!</b> <b>The calibration value must comply with the operating limits specified on the plate.</b>
8	Disconnect the external pressure source from the pressure switch sensing line.
9	Reconnect the sensing line between pressure switch and line.

*Tab. 8.40.*

### 8.5.2.2 - CALIBRATION PROCEDURE WITH MAIN REGULATOR

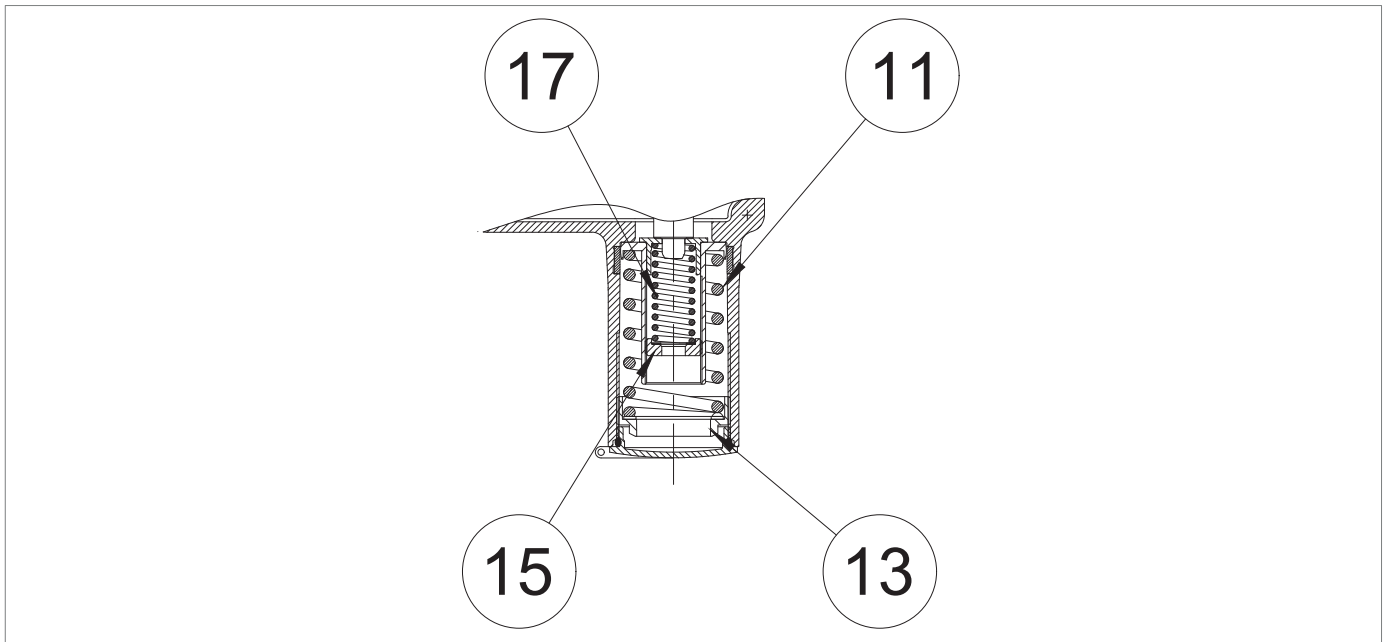

Fig. 8.13. Calibration of pressure switches Mod.100

### SPRING CALIBRATION FOR MAXIMUM PRESSURE TRIP

Step	Action
1	<p>By acting on the main regulator, increase the downstream pressure up to the tripping value of the slam-shut valve, to check for proper calibration.</p> <div style="border: 1px solid blue; padding: 5px;"> <p><b>! NOTE!</b></p> <p><b>Check the pressure referring to the pressure gauge (fig. 8.11, ref. 5) downstream of the main regulator.</b></p> <p><b>If the slam-shut valve:</b></p> <ul style="list-style-type: none"> <li>• <b>trips before the expected pressure value: screw in (clockwise) the adjustment ring nut (13) so as to further compress the spring (11);</b></li> <li>• <b>does not trip at the expected pressure value: unscrew (anticlockwise) the adjustment ring nut (13) so as to relieve the spring (11).</b></li> </ul> </div>
2	By opening the vent (fig.8.11, ref. 6), decrease the pressure in the downstream section to the calibration value of the main regulator.
3	Close the vent (fig.8.11, ref. 6).
4	Trigger the slam-shut device by operating the lever in the 3/2 valve (fig. 4.1, ref. 8).
5	<p>Repeat steps 2-3-4 at least three times.</p> <div style="border: 1px solid blue; padding: 5px;"> <p><b>! NOTE!</b></p> <p><b>The calibration value must comply with the operating limits specified on the plate.</b></p> </div>

Tab. 8.41.

**SPRING CALIBRATION FOR MINIMUM PRESSURE TRIP (IF ANY)**

Step	Action
1	Open the vent (fig.8.11, ref. 6) to the atmosphere and keep it open for the next steps.
2	<p>Decrease the downstream pressure to the minimum tripping pressure of the slam-shut device by adjusting the pilot.</p> <div style="border: 1px solid blue; padding: 5px;"> <p><b>! NOTE!</b></p> <p><b>Check the pressure referring to the downstream pressure gauge (fig. 8.11, ref. 5).</b></p> <p><b>If the slam-shut valve:</b></p> <ul style="list-style-type: none"> <li>• <b>trips before the expected pressure value: unscrew (anticlockwise) the adjustment ring nut (15) so as to relieve the spring (17);</b></li> <li>• <b>does not trip before the expected pressure value, screw in (clockwise) the adjustment ring nut (15) so as to further compress the spring (17).</b></li> </ul> </div>
3	Close the vent (fig.8.11, ref. 6).
4	Balance the upstream and downstream pressure of the slam-shut valve using the HP2/2 bypass valve (fig.8.4, ref. 7.1).
5	Open the vent again (fig. 8.11, ref. 6).
6	Increase the downstream pressure up to the set value by acting on the main regulator.
7	Trigger the slam-shut device by operating the lever in the 3/2 valve (fig. 4.1, ref. 8).
8	<p>Check the correct calibration of the main regulator.</p> <div style="border: 1px solid blue; padding: 5px;"> <p><b>! NOTE!</b></p> <p><b>The calibration value must comply with the operating limits specified on the plate.</b></p> </div>
9	Check the minimum pressure spring for proper calibration by repeating steps 2-3-4 at least three times.
10	Close the vent (fig.8.11, ref. 6).
11	Check the maximum pressure spring for proper calibration by repeating steps 2-3-4 of table 8.41 at least three times.

*Tab. 8.42.*

**8.5.3 - PROCEDURE FOR COMMISSIONING THE EQUIPMENT WITH LINE OFF 2.0**

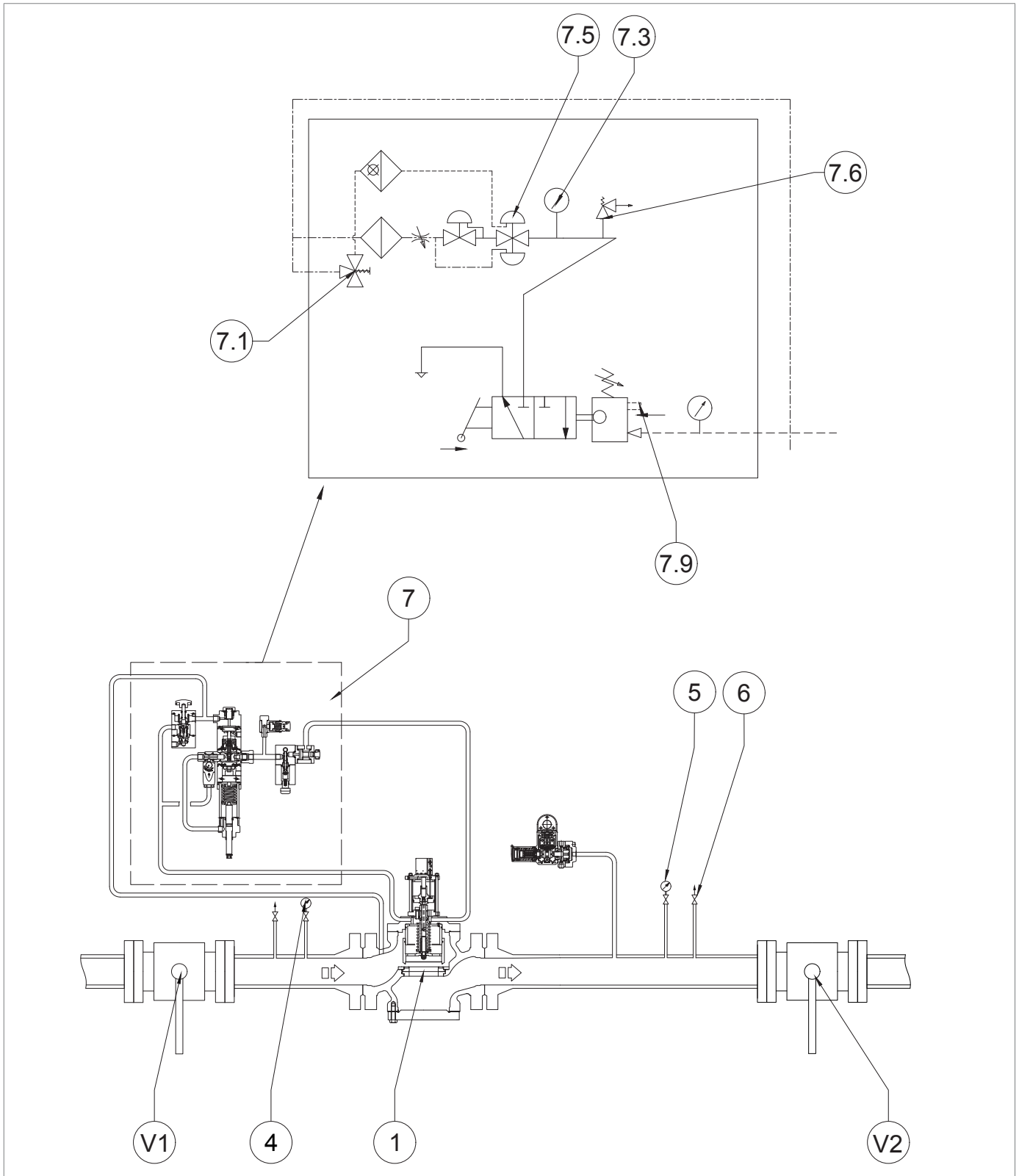



Fig. 8.14. LINE OFF 2.0 commissioning and calibration for HBC 975

Step	Action
1	Press and hold the button of the bypass valve HP2/2 (7.1) to: <ul style="list-style-type: none"> <li>bring the upstream pressure to the LINE-OFF 2.0 power supply unit;</li> <li>balance the pressure of the HBC 975 built-in slam-shut valve plug.</li> </ul>
2	Release the button of bypass valve HP2/2 (7.1) after checking that the upstream and downstream pressure of the slam-shut valve is balanced.
3	Turn the adjustment screw of the R44/SS regulator (7.5) clockwise and tighten it until reaching the tripping value (6 bar) of the safety valve VS/FI (7.6). <div style="border: 1px solid black; padding: 5px; margin-top: 10px;"> <p> <b>NOTE!</b>  <b>Check the pressure, referring to the pressure gauge (7.3) connected to the R44/SS regulator.</b></p> </div>
4	If the safety valve VS/FI (7.6): <ul style="list-style-type: none"> <li>opens before the expected pressure value, unscrew the locking ring nut and tighten (clockwise) the adjustment plug so that the spring inside it is further compressed;</li> <li>does not open at the expected pressure value, unscrew the locking ring nut and loosen the adjustment cap anticlockwise, so as to release the spring inside.</li> </ul>
5	Check the VS/FI valve (7.6) for correct calibration: <ul style="list-style-type: none"> <li>decreasing the pressure by acting on the adjustment screw of the R44/SS regulator (7.5);</li> <li>increasing the pressure until the VS/FI valve (7.6) trips by acting on the adjustment screw of the R44/SS regulator (7.5).</li> </ul>
6	Repeat step 5 at least three times to properly calibrate the VS/FI safety valve (7.6).
7	By acting on the adjustment screw, calibrate the R44/SS regulator (7.5) to the required pressure value (min. 4 bar, max. 5 bar) referring to the connected pressure gauge (7.3), then: <ul style="list-style-type: none"> <li>if the pressure value on the pressure gauge is lower than the set value of the R44/SS regulator (7.5): tighten the adjustment screw clockwise so as to further compress the spring inside it;</li> <li>if the pressure value on the pressure gauge is higher than the calibration value of the R44/SS regulator (7.5): unscrew the adjustment screw anticlockwise so as to further release the spring inside.</li> </ul>
8	Press the button of bypass valve HP2/2 (7.1) and check that the upstream and downstream pressure is balanced.
9	Release the HP2/2 bypass valve button (7.1).
10	Trigger the HBC 975 slam-shut valve by operating the lever (7.9).

Tab. 8.43.



# 1 - MAINTENANCE AND FUNCTIONAL CHECKS

## 1.1 - GENERAL WARNINGS

### **HAZARD!**

- **Maintenance work must be carried out by qualified personnel trained on safety in the workplace and authorised to carry out equipment-related activities.**
- **Each maintenance operation requires in-depth and specialised knowledge of the equipment, the necessary operations, the associated risks and the correct procedures to operate safely.**
- **Repair or maintenance work not provided for in this manual may be carried out only if approved by the PIETRO FIORENTINI S.p.A.. PIETRO FIORENTINI S.p.A. shall not be held liable for damage to persons or property resulting from operations other than those described herein or carried out in ways other than as indicated.**

### **WARNING!**

**Before conducting any work, make sure that the line on which the equipment is installed:**

- **has been shut off downstream and upstream;**
- **has been discharged.**

### **WARNING!**

**In case of doubt, do not perform any work. Contact PIETRO FIORENTINI S.p.A. for the necessary clarifications.**

Managing and/or using the equipment includes operations that are necessary as a result of normal use such as:

- inspection and checks;
- functional checks;
- routine maintenance;
- special maintenance.

### **NOTE!**

**Maintenance work is strictly related to:**

- **the quality of the conveyed gas (impurities, humidity, gasoline, corrosive substances);**
- **the effectiveness of filtration;**
- **the equipment conditions of use.**

To properly run the equipment, one should:

- follow the service frequency referred to in the manual for functional checks and routine maintenance.
- not exceed the time interval between one service and the next. The time interval is to be understood as the maximum acceptable; it can, however, be shortened;
- promptly check the cause of any anomalies such as excessive noise, leakage of fluids or similar, and remedy them. Promptly remove any causes of faults and/or malfunctions to prevent further damage to the equipment and ensures operator safety.

Before beginning disassembly of the equipment, make sure that:

- the spare parts and parts used in replacements have adequate requirements to ensure the original performance of the equipment. Use only compliant spare parts;
- the operator has the necessary equipment (see chapter 7 “Equipment for commissioning/maintenance”).

**! NOTE!**

**The recommended spare parts are unambiguously identified with tags indicating:**

- **the assembly drawing number of the equipment where they are installed (see Chapter 12 “Recommended spare parts”);**
- **The position specified in the assembly drawing of the equipment.**

The equipment maintenance operations are divided, from an operational point of view, into three main categories:

Commissioning and maintenance operations	
<b>Periodic checks and inspections</b>	All those checks that the operator must carry out on a regular basis to ensure that the equipment is in proper working order.
<b>Routine maintenance</b>	All those operations that the operator must preventively carry out to ensure proper operation of the device over time. Maintenance includes the: <ul style="list-style-type: none"> <li>• inspection;</li> <li>• control;</li> <li>• adjustment;</li> <li>• cleaning;</li> <li>• lubrication;</li> <li>• replacement;</li> </ul> of all spare parts.
<b>Special maintenance</b>	All those operations to be carried out by the operator as required by the equipment.

Tab. 1.44.



## 1.2 - PERIODICALLY CHECKING AND INSPECTING THE EQUIPMENT FOR PROPER OPERATION

Periodic checks and inspections	
<b>Operator qualification</b>	Mechanical maintenance technician
<b>PPE required</b>	 <p><b>WARNING!</b></p> <p>The PPE listed in this table is related to the risk associated with the equipment. For the PPE required to protect against risks associated with the workplace, installation or operating conditions, please refer to:</p> <ul style="list-style-type: none"> <li>the regulations in force in the country of installation;</li> <li>any information provided by the Safety Manager at the installation facility.</li> </ul>

Tab. 1.45.

Table 9.46 lists the checks and inspections, i.e. the operations that do not require any manual service on the equipment. Some items thereof can be replaced remotely using suitable remote control tools.

Activity description	Equipment/accessories involved	Evaluation criterion	Minimum frequency
<b>Significant performance* check</b>	Pressure regulators	<ul style="list-style-type: none"> <li>No fluctuations in the adjusted pressure.</li> <li>Significant pressure values within pre-set limits.</li> </ul>	Monthly
	Gas flow lock type safety devices (external position indicator)	<ul style="list-style-type: none"> <li>Fully opening position.</li> </ul>	
	Stand-by monitor (external position indicator)	<ul style="list-style-type: none"> <li>Fully opening position.</li> </ul>	
<b>Visual inspection of the equipment outside condition</b>	All	<ul style="list-style-type: none"> <li>No visible damage.</li> <li>External surface protection as per UNI 9571-1:2012.</li> </ul>	Half-yearly

Tab. 1.46.

\* These checks may be carried out remotely if there is a remote control system capable of analysing the significant performance of the equipment and of sending alerts/alarms when pre-set thresholds are reached.

## 1.3 - ROUTINE MAINTENANCE

### 1.3.1 - GENERAL SAFETY WARNINGS

 **HAZARD!**

- Put the equipment in a safe condition (close the downstream shut-off valve and then the upstream one, and drain the line completely);
- Ensure that the pressure upstream and downstream of the equipment is “0”.

 **NOTE!**

Before installing new sealing elements (o-rings, diaphragm, etc.), they must be checked for integrity.

### 1.3.2 - REPLACEMENT FREQUENCY FOR COMPONENTS SUBJECT TO WEAR

**NOTE!**

The following provisions shall apply to equipment components only.

The non-metallic parts of the equipment concerned are divided into the following two categories:

**Preventive maintenance work**

<b>Category 1</b>	Parts subject to wear and/or abrasion, where: <ul style="list-style-type: none"> <li>wear and tear means the normal degradation of a part after prolonged use under normal operating conditions;</li> <li>abrasion is the mechanical action on the surface of the affected part resulting from the passage of gas under normal operating conditions.</li> </ul>
<b>Category 2</b>	Parts subject to aging only, including parts that also require lubrication and/or cleaning.

Tab. 1.47.

**NOTE!**





Check, within the minimum frequency specified in Table 9.48, the available components for wear/abrasion/aging.

Category	Part description	Evaluation criterion	Minimum replacement frequency
1	Sealing rings for non-metallic valve seats and plugs	Pressure regulators	6 years
		Safety devices	
		Pressure safety system equipment	
1	Non-metallic parts with internal sealing function of valve seats and accessories of individual equipment	Pilots	6 years
		Pre-regulators	
		Accelerators	
		Others possible	
1	Non-metallic parts with a sealing function between parts, at least one of which is in motion under normal working/operating conditions	Pressure regulators	6 years
		Gas flow slam-shut type safety devices	
		Relief devices with discharge to atmosphere	
1	Non-metallic parts with sealing function involved in disassembly operations during maintenance	Equipment subject to maintenance	6 years
2	Non-metallic parts providing feedback (sensing elements) of the controlled pressure of safety equipment	Safety equipment and/or accessories	6 years
2	Non-metallic parts with sealing and performance functions (diaphragms) of equipment	Pressure regulators and accessories	6 years
		Gas flow slam-shut type safety devices	6 years
		Relief device with discharge to atmosphere	6 years
2	Non-metallic parts of equipment with an internal sealing function: under normal operating conditions during maintenance	Relief valves	6 years
		Regulation lines disconnection equipment	If there are proven leaks
2	Non-metallic parts with a static sealing function only	Various equipment	If there are proven leaks

Category	Part description	Evaluation criterion	Minimum replacement frequency
2	Lubricating parts	Shut-off valves	Yearly
		Other equipment	Yearly
2	Filter elements	Filters	As needed

Tab. 1.48.

## 1.4 - ROUTINE MAINTENANCE PROCEDURES

Routine maintenance	
<b>Operator qualification</b>	Mechanical maintenance technician
<b>PPE required</b>	<div style="display: flex; justify-content: space-around; align-items: center;">      </div> <div style="background-color: #f4a460; padding: 5px; margin-top: 5px;"> <b>⚠ WARNING!</b> </div> <p>The PPE listed in this table is related to the risk associated with the equipment. For the PPE required to protect against risks associated with the workplace, installation or operating conditions, please refer to:</p> <ul style="list-style-type: none"> <li>the regulations in force in the country of installation;</li> <li><u>any information provided by the Safety Manager at the installation facility.</u></li> </ul>
<b>Necessary equipment</b>	Refer to chapter 7 "Equipment for commissioning/maintenance".

Tab. 1.49.



**HBC 975 DN 4"**

Pos.	Description	Torque (Nm)	Torque (ft - lb)
9	Locking nut M12X1.25	35	25
11	M12X1.25 balancing piston guide	35	25
27	Screw M10X40 UNI 5737	45	33
32	Screw M16X50 UNI 5737	150	110
33	Nut M12X1.25 UNI 5589	35	25
67	Nut M12 UNI 5588	80	59
81	Screw M8X16 UNI 5931	20	14
87	Screw M6X16 UNI 5931	10	7
89	Screw M6X16 UNI 5931	10	7

*Tab. 1.50.*
**HBC 975 DN 6"**

Pos.	Description	Torque (Nm)	Torque (ft - lb)
9	Locking nut M24X1.5	110	81
11	M18X1.5 balancing piston guide	110	81
27	Screw M14X50 UNI 5737	115	84
32	Screw M20x60 UNI 5737	250	184
33	Nut M18X1.5 UNI 5589	110	81
67	Nut M16 UNI 5588	200	147
81	Screw M8X20 UNI 5931	20	14
86	Screw M6X25 UNI 5931	10	7
89	Screw M6X16 UNI 5931	10	7

*Tab. 1.51.*
**HBC 975 DN 8"**

Pos.	Description	Torque (Nm)	Torque (ft - lb)
9	Locking nut M24X1.5	110	81
11	M18X1.5 balancing piston guide	110	81
27	Screw M14X50 UNI 5737	115	84
32	Screw M22x70 UNI 5737	280	206
33	Nut M18X1.5 UNI 5589	110	81
67	Nut M16 UNI 5588	200	147
81	Screw M8X20 UNI 5931	20	14
86	Screw M6X25 UNI 5931	10	7
89	Screw M6X16 UNI 5931	10	7

*Tab. 1.52.*





**HBC 975 DN 10"**

Pos.	Description	Torque (Nm)	Torque (ft - lb)
9	Locking nut M30X1.5	150	110
11	M22X1.5 balancing piston guide	150	110
27	Screw M20X70 UNI 5931	250	184
32	Screw M22x70 UNI 5737	280	206
33	Nut M20X1.5 UNI 5589	150	110
67	Nut M16 UNI 5588	200	147
81	Screw M8X20 UNI 5931	20	14
86	Screw M6X25 UNI 5931	10	7
89	Screw M6X16 UNI 5931	10	7

*Tab. 1.53.*
**HBC 975 DN 12"**

Pos.	Description	Torque (Nm)	Torque (ft - lb)
9	Locking nut M30X1.5	150	110
11	M22X1.5 balancing piston guide	150	110
27	Screw M20X70 UNI 5931	250	184
32	Screw M22x100 UNI 5737	280	206
33	Nut M20X1.5 UNI 5589	150	110
67	Nut M16 UNI 5588	200	147
81	Screw M8X20 UNI 5931	20	14
86	Screw M6X25 UNI 5931	10	7
89	Screw M6X16 UNI 5931	10	7

*Tab. 1.54.*

**1.4.1.1 - TIGHTENING TORQUES FOR HP2/2 BYPASS DEVICE**

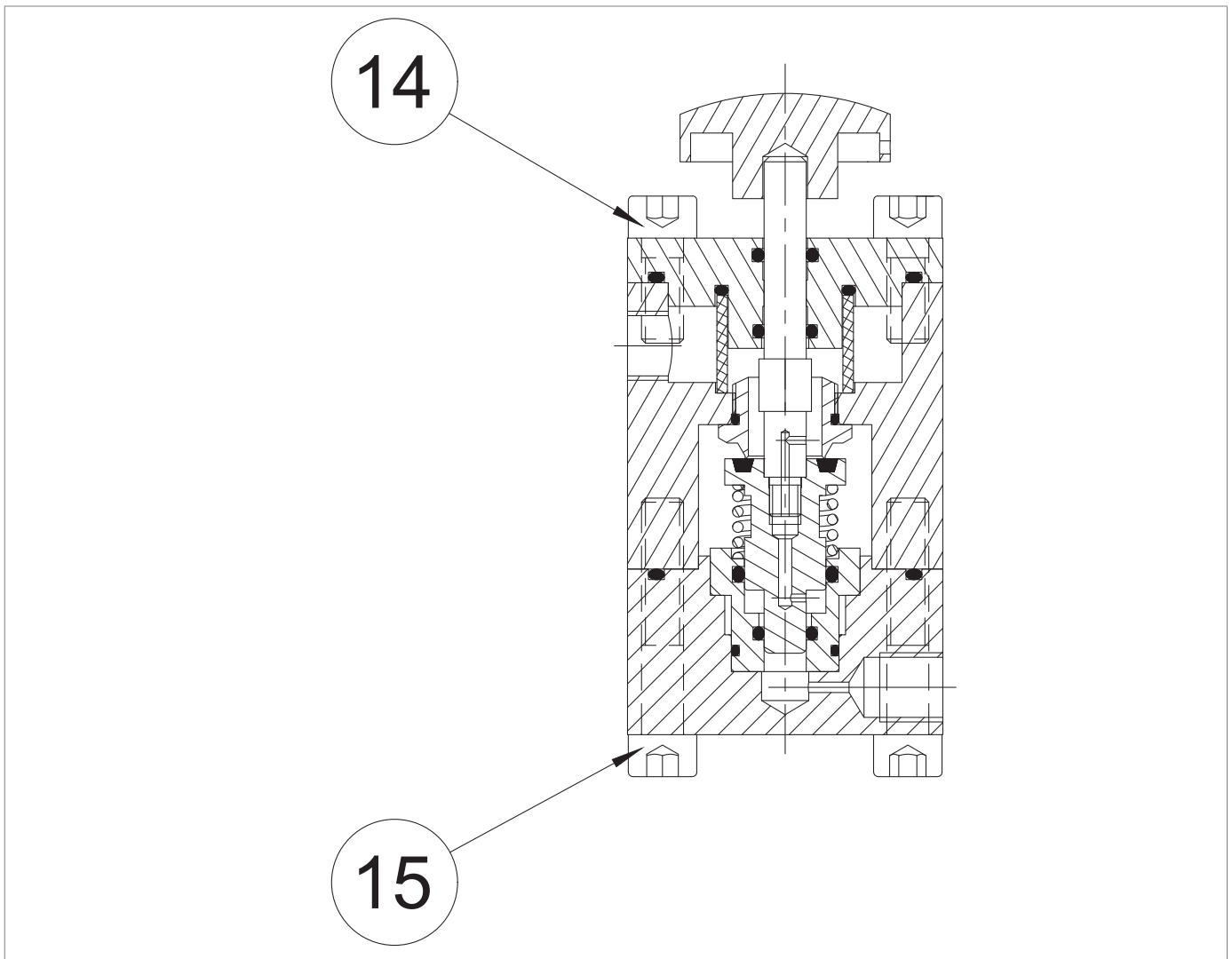

Fig. 1.16. Tightening torques for HP2/2 bypass device

HP2/2			
Pos.	Description	Torque (Nm)	Torque (ft - lb)
14	Screw M8X20 UNI 5931	16	11
15	Screw M8X45 UNI 5931	16	11

Tab. 1.55.

### 1.4.1.2 - TIGHTENING TORQUES FOR R44/SS REGULATOR

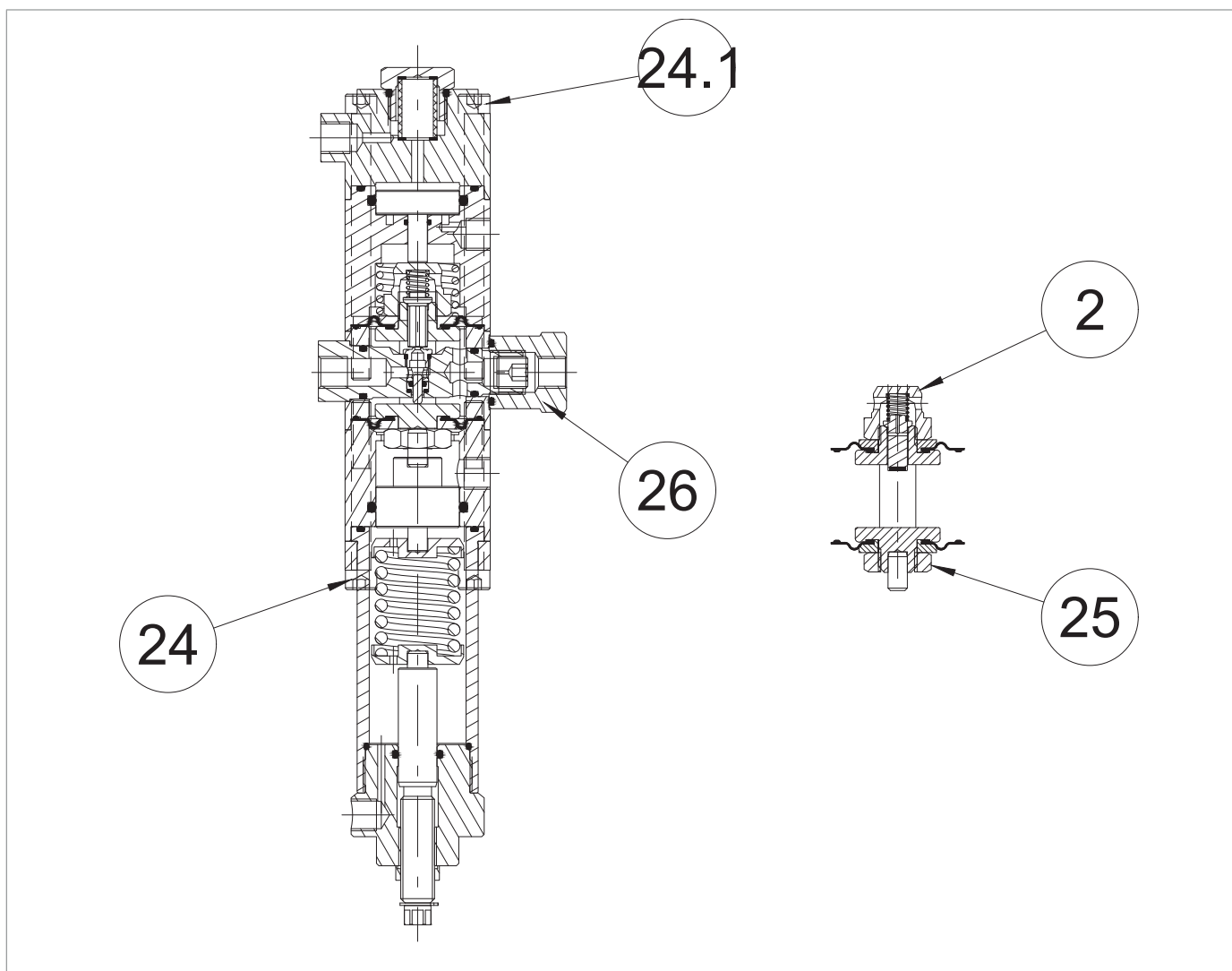

Fig. 1.17. Tightening torques for R44/SS regulator

R44/SS			
Pos.	Description	Torque (Nm)	Torque (ft - lb)
2	Nut M16X1	25	18
24	Screw M8X110 UNI 5931	16	11
24.1	Screw M8X70 UNI 5931	16	11
25	Nut M16X1.5	25	18
26	Nut M18X1.5	20	14

Tab. 1.56.

### 1.4.1.3 - TIGHTENING TORQUES FOR LAMINATION VALVE AR100

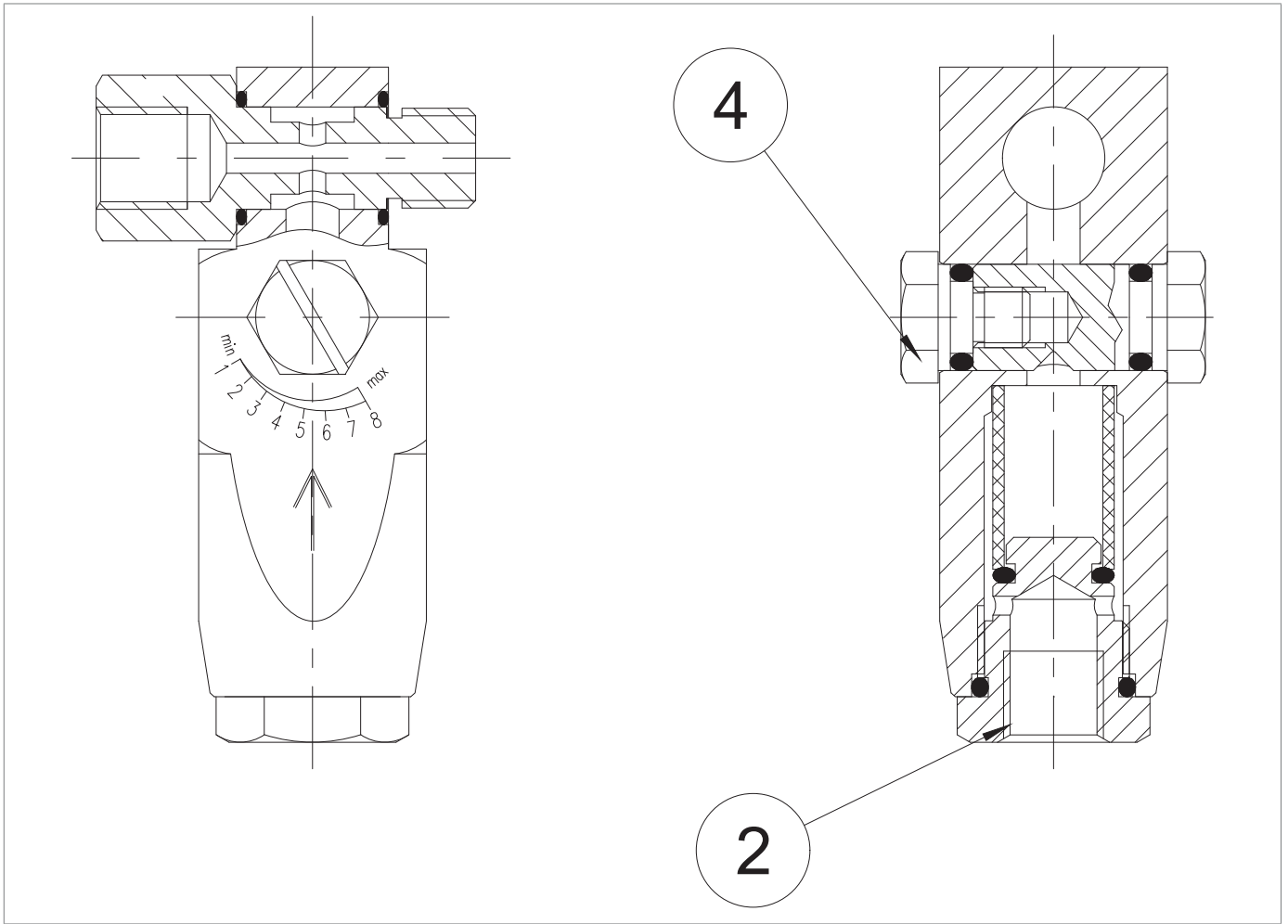

Fig. 1.18. Tightening torques for lamination valve AR100

AR100			
Pos.	Description	Torque (Nm)	Torque (ft - lb)
2	Cap M20X1.5	20	14
4	Screw M8	4	2

Tab. 1.57.



**1.4.1.4 - TIGHTENING TORQUES FOR PRESSURE SWITCHES MODELS 102M/102MH - 105M/105MH**

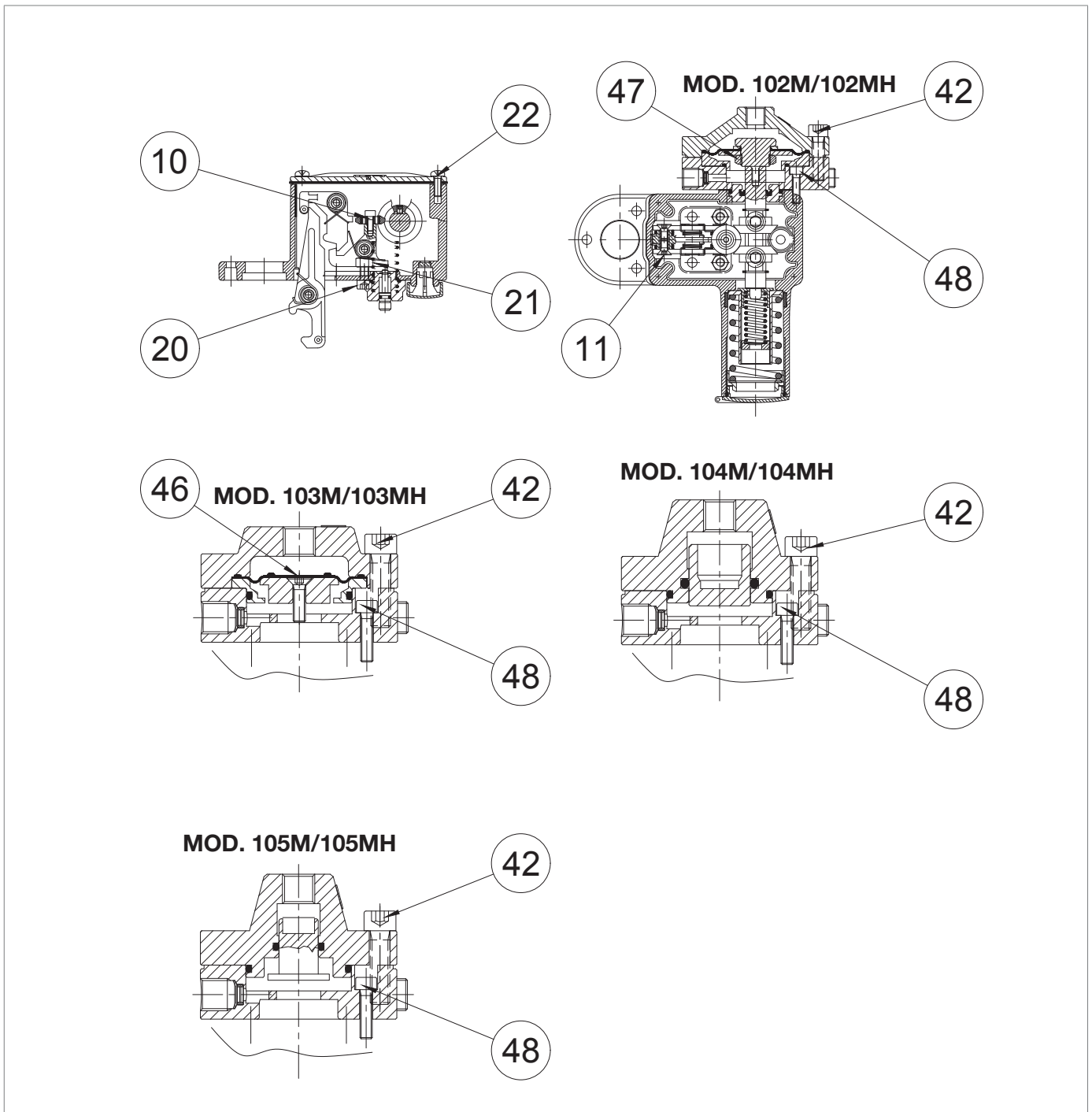

Fig. 1.19. Tightening torques for pressure switches models 102M/102MH - 105M/105MH

**MOD. 102M/102MH**

Pos.	Description	Torque (Nm)	Torque (ft - lb)
10	Screw M4X10 UNI 5931	3	2
11	Screw M5X10 UNI 5933	5	3
20	Screw M6X16 UNI 5931	10	7
21	Nut M6 UNI 5588	10	7
22	Screw M5X15 UNI 8112	5	3
42	Screw M6X25 UNI 5931	16	11
47	Nut M20X1	8	5
48	Screw M5X16 UNI 5931	5	3

*Tab. 1.58.*
**MOD. 103M/103MH**

Pos.	Description	Torque (Nm)	Torque (ft - lb)
10	Screw M4X10 UNI 5931	3	2
11	Screw M5X10 UNI 5933	5	3
20	Screw M6X16 UNI 5931	10	7
21	Nut M6 UNI 5588	10	7
22	Screw M5X15 UNI 8112	5	3
42	Screw M8X30 UNI 5931	16	11
46	Screw M5X18 UNI 5931	8	5
48	Screw M5X20 UNI 5931	5	3

*Tab. 1.59.*
**MOD. 104M/104MH - 105M/105MH**

Pos.	Description	Torque (Nm)	Torque (ft - lb)
10	Screw M4X10 UNI 5931	3	2
11	Screw M5X10 UNI 5933	5	3
20	Screw M6X16 UNI 5931	10	7
21	Nut M6 UNI 5588	10	7
22	Screw M5X15 UNI 8112	5	3
42	Screw M8X30 UNI 5931	16	11
48	Screw M5X20 UNI 5931	5	3

*Tab. 1.60.*





## 1.4.2 - REPLACING ELEMENTS SUBJECT TO WEAR AND ABRASION

### 1.4.2.1 - INITIAL OPERATIONS

#### ATTENTION!

Before carrying out any work, ensure that the line on which the equipment is installed has been shut off upstream and downstream and discharged.

#### ATTENTION!

During assembly, make sure to tighten the screws as per the tables (tightening torques), according to the size for which maintenance is being carried out.

### 1.4.2.2 - CROSS DIAGRAM FOR TIGHTENING SCREWS

To tighten the screws, when required by the maintenance procedure, refer to the following diagram:

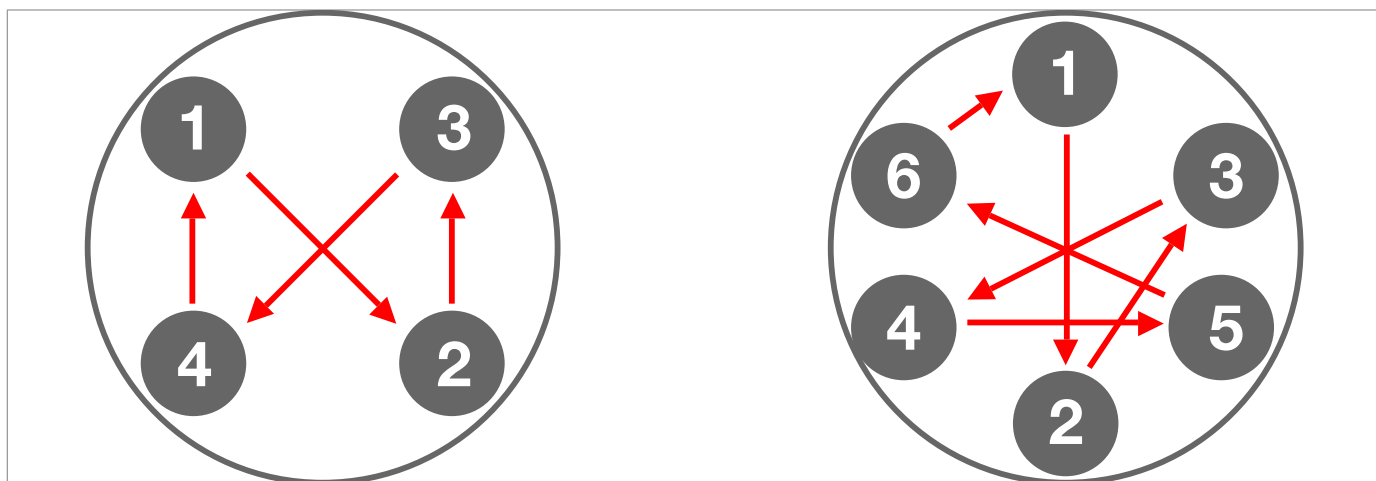

Fig. 1.20. Cross diagram

**1.4.3 - LINE OFF 2.0 DISCONNECTION PROCEDURE**

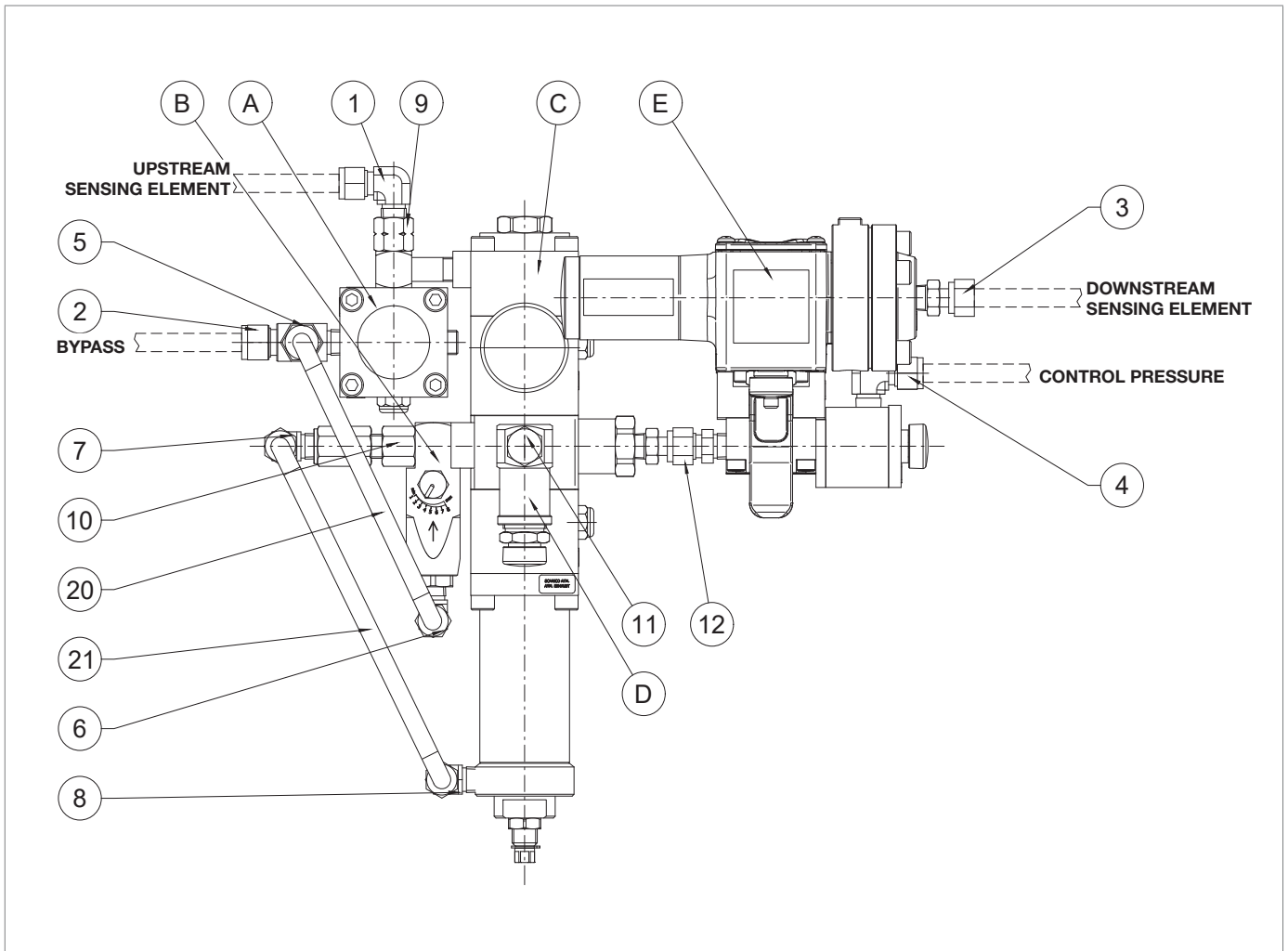

Fig. 1.21. LINE OFF 2.0

Before proceeding with maintenance, disconnect the LINE OFF 2.0 device as shown in table 9.61.

Step	Action
1	Disconnect the pipes from the fittings (1, 2, 3, 4).
2	Unscrew and remove the fixing screw to disconnect the LINE OFF 2.0.
3	Disconnect the pipe (20) from the fittings (5, 6).
4	Disconnect the pipe (21) from the fittings (7, 8).
5	Remove assembly "A" (bypass device <b>HP2/2</b> ) and adjust the fitting (9).
6	Remove assembly "B" (lamination valve <b>AR100</b> ) and adjust the fitting (10).
7	Remove assembly "D" (safety valve <b>VS/FI</b> ) and adjust the fitting (11).
8	Remove assembly "E" (valve <b>3/2</b> and control pressure switch) from assembly "C" (regulator <b>R44/SS</b> ) and adjust the fitting (12).

Tab. 1.61.

**1.4.4 - HBC 975 BUILT-IN SLAM-SHUT VALVE MAINTENANCE PROCEDURE**

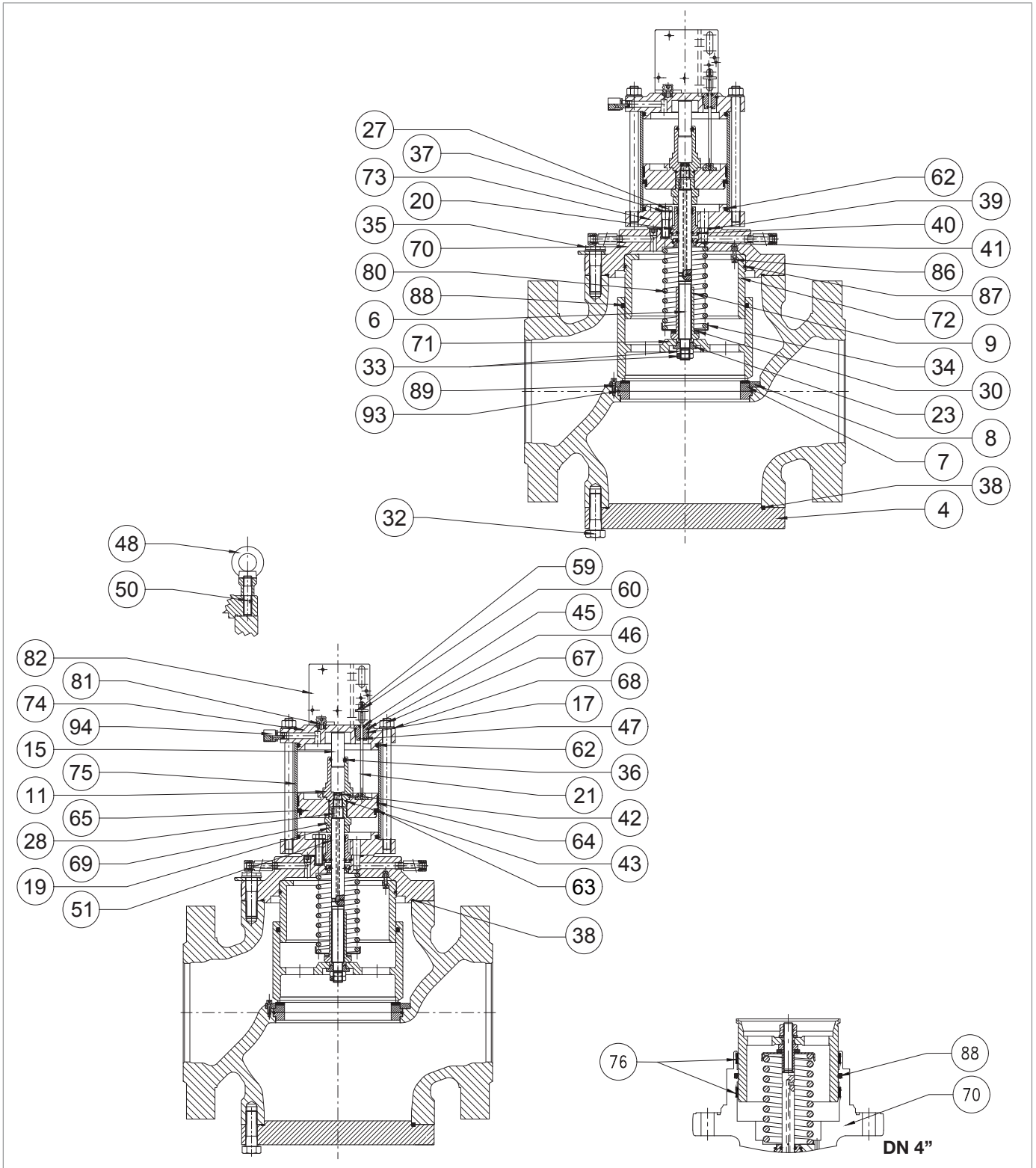
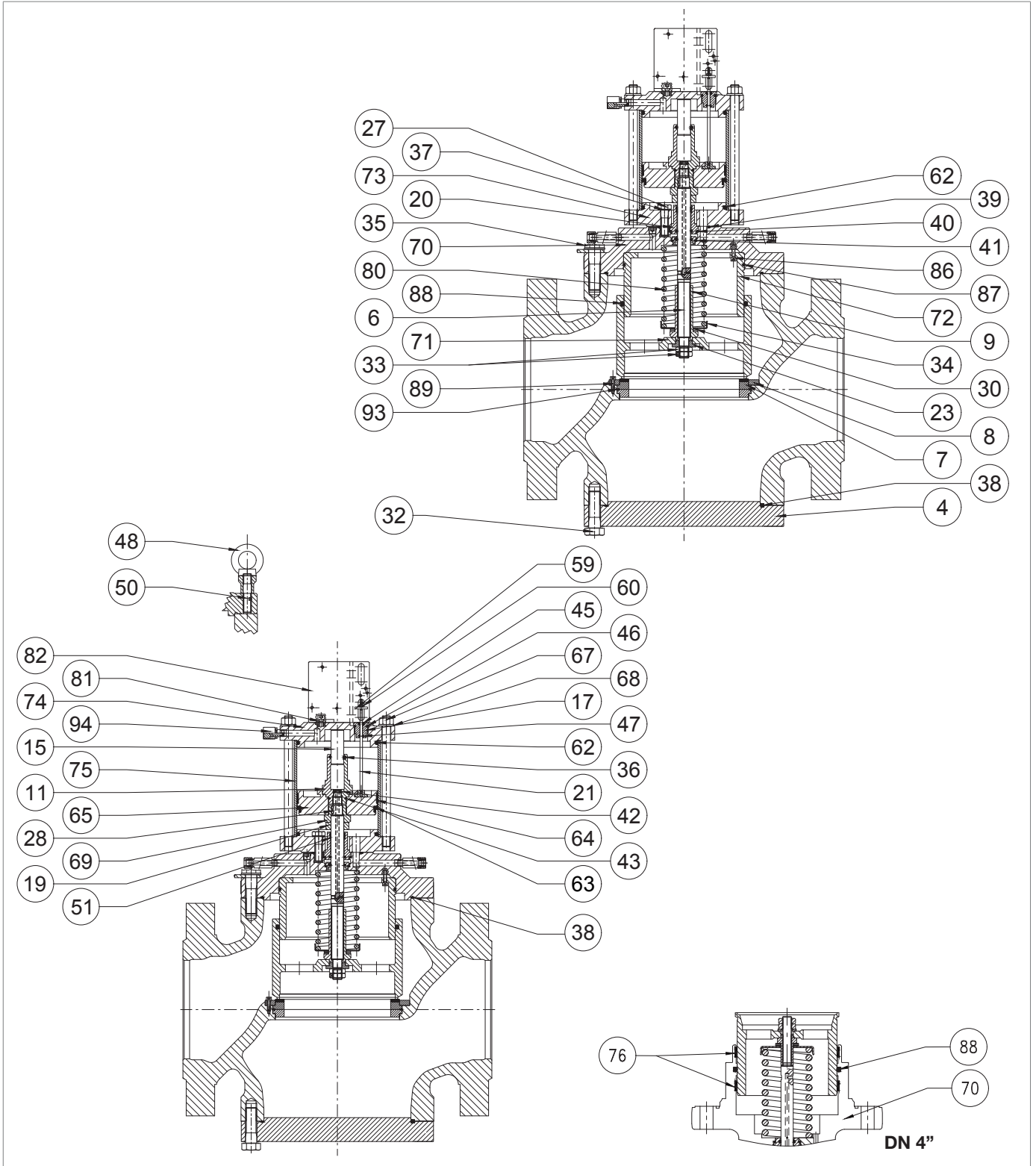

Fig. 1.22. HBC 975 Slam-shut valve

Step	Action
1	<p><b>! NOTE!</b></p> <p><b>To disconnect the LINE OFF 2.0 device, refer to paragraph 9.4.3. tab. 9.61.</b></p>
2	Undo and remove the screws (81).
3	Remove the bracket (82).
4	Unscrew and remove the nut (60) together with the indicator disc (59).
5	Unscrew and remove the nut (17).
6	Pull out the indicator rod (21).
7	<p>Remove the guide O-ring (45) from the nut (17) and replace it, taking care to lubricate it with synthetic grease.</p> <p><b>! NOTE!</b></p> <p><b>Before inserting the replacement guide ring, clean the retaining slots with a cleaning solution.</b></p>
8	<p>Remove the O-rings (46, 47) from the nut (17) and replace them, taking care to lubricate them with synthetic grease.</p> <p><b>! NOTE!</b></p> <p><b>Before inserting the replacement O-rings, clean the retaining slots with a cleaning solution.</b></p>
9	<p>Undo and remove the screws (35).</p> <p><b>! NOTE!</b></p> <p><b>If the HB/97 built-in slam-shut valve is in the inverted position, support it during this step to prevent any falls.</b></p>
10	Remove the HB/97 built-in slam-shut valve and fit it vertically with the plug (71) on an anti-shock surface.
11	Undo and remove the screws (89).
12	Remove the locking ring (8).
13	Remove and replace the reinforced gasket (7).
14	<p>Remove the O-ring (93) and replace it, taking care to lubricate it with synthetic grease.</p> <p><b>! NOTE!</b></p> <p><b>Before inserting the replacement O-rings, clean the retaining slots with a cleaning solution.</b></p>
15	Put the reinforced gasket (7) back in place.
16	Put the locking ring (8) back in place.
17	<p>Insert and fix the screws (89) according to the following tightening torques:</p> <ul style="list-style-type: none"> <li>• DN 4" &gt; tab. 9.50;</li> <li>• DN 6" &gt; tab. 9.51;</li> <li>• DN 8" &gt; tab. 9.52;</li> <li>• DN 10" &gt; tab. 9.53;</li> <li>• DN 12" &gt; tab. 9.54.</li> </ul> <p><b>! NOTE!</b></p> <p><b>Tighten the screws according to the cross diagram in paragraph 9.4.2.2.</b></p>



HBC 975 Slam-shut valve

Step	Action
18	Unscrew and remove the nuts (67) together with the washers (68).
19	Remove the flange (74). <b>NOTE!</b> <b>Check that the vent (94) is not clogged by dirt.</b>
20	Remove the O-ring (62) from the flange (74) and replace it, taking care to lubricate it with synthetic grease. <b>NOTE!</b> <b>Before inserting the replacement O-ring, clean the retaining slots with a cleaning solution.</b>
21	Remove the plating (75).
22	Fit the HB/97 built-in slam-shut valve sideways.
23	Unscrew and remove the nuts (33) together with the washer (23).
24	Remove the plug (71) and place it on an anti-shock surface.
25	<b>APPLICABLE TO DN 4" ONLY</b> Remove the O-ring (88) from the plug guide (70) and replace it, taking care to lubricate it with synthetic grease. <b>NOTE!</b> <b>Before inserting the O-ring, clean the retaining slots with a cleaning solution.</b>
26	<b>APPLICABLE TO DN 4" ONLY</b> Remove the I/DWR rings (76) from the plug guide (70) and replace it, taking care to lubricate it with synthetic grease. <b>NOTE!</b> <b>Before inserting the I/DWR rings, clean the retaining slots with a cleaning solution.</b>
27	Remove the O-ring (88) from the plug (71) and replace it, taking care to lubricate it with synthetic grease. <b>NOTE!</b> <b>Before inserting the replacement O-ring, clean the retaining slots with a cleaning solution.</b>
28	While keeping the nut (69) in place, unscrew and remove the lock nut (9). <b>NOTE!</b> <b>By unscrewing the lock nut (9), the spring (80) is released.</b>
29	Remove the radial bearing (30).
30	Remove the spring support (34) and the spring (80).
31	While keeping the nut (69) in place, unscrew and remove the balancing piston guide (11).
32	Remove the balancing piston (15) from the balancing piston guide (11).
33	Remove the O-rings (36, 43) from the balancing piston guide (11) and replace them, taking care to lubricate them with synthetic grease. <b>NOTE!</b> <b>Before inserting the replacement O-rings, clean the retaining slots with a cleaning solution.</b>

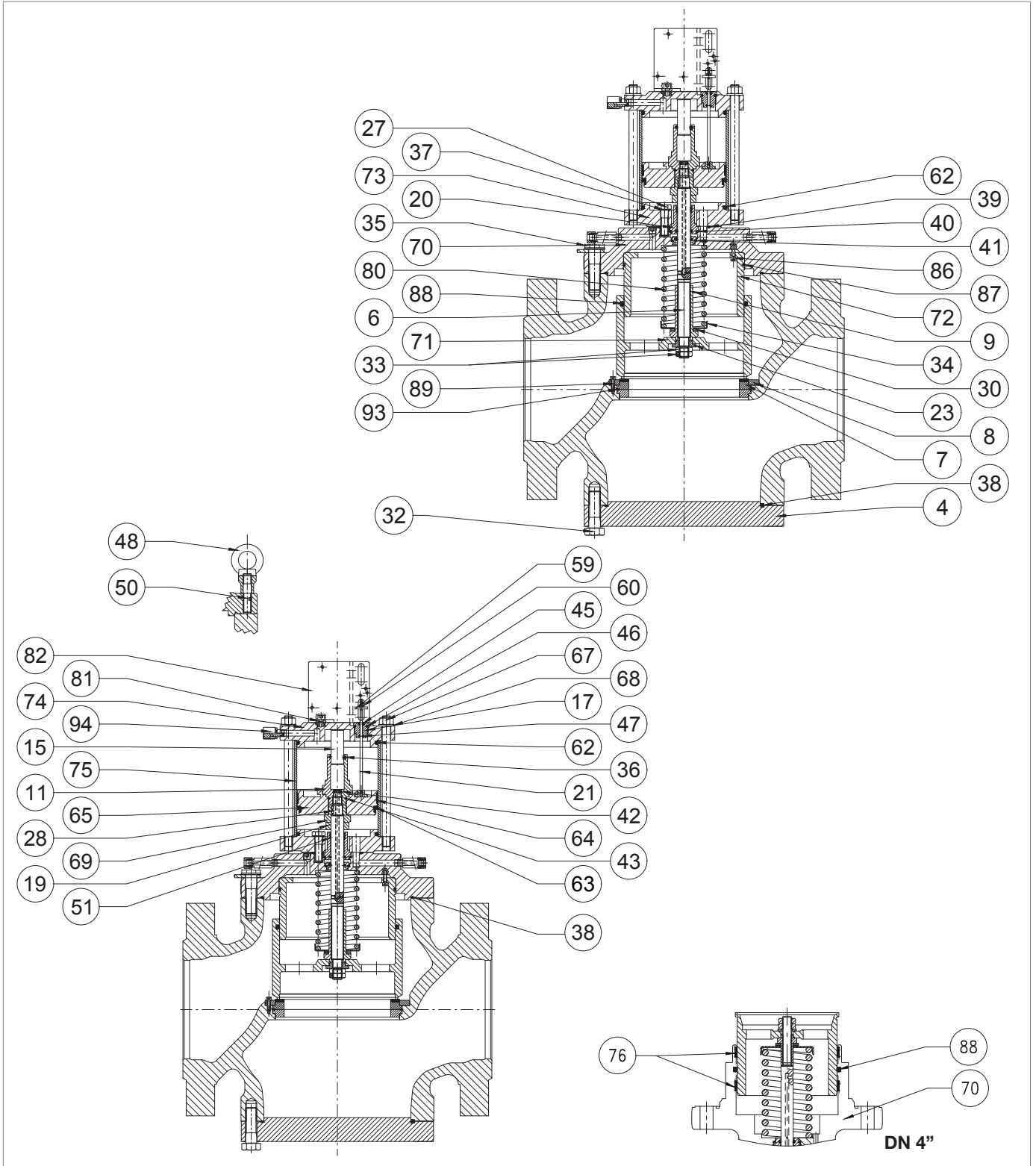

HBC 975 Slam-shut valve



Step	Action
34	Fit the balancing piston (15) from the balancing piston guide (11).
35	Take out the piston (65).
36	Remove the U-shaped ring (63) from the bush (65) and replace it, taking care to lubricate it with synthetic grease.  <div style="border: 1px solid black; padding: 5px;"> <p><b>! NOTE!</b></p> <ul style="list-style-type: none"> <li>• <b>Before inserting the replacement U-ring, clean the retaining slots with a cleaning solution.</b></li> <li>• <b>The concave part must face the flange (73).</b></li> </ul> </div>
37	Remove the I/DWR ring (64) from the piston (65) and replace it, taking care to lubricate it with synthetic grease.  <div style="border: 1px solid black; padding: 5px;"> <p><b>! NOTE!</b></p> <p><b>Before inserting the replacement I/DWR ring, clean the retaining slots with a cleaning solution.</b></p> </div>
38	Take out the nut (69).
39	<b>APPLICABLE TO DN 6" - 12" ONLY</b> Remove the spacer (19).
40	Undo and remove the screws (27) together with the washer (37).
41	Remove the flange (73).
42	Remove the O-ring (62) from the flange (73) and replace it, taking care to lubricate it with synthetic grease.  <div style="border: 1px solid black; padding: 5px;"> <p><b>! NOTE!</b></p> <p><b>Before inserting the replacement O-ring, clean the retaining slots with a cleaning solution.</b></p> </div>
43	Remove the stem guide (20) together with the stem (6) and the key (28).
44	Remove the stem (6) from the stem guide (20).
46	Remove the I/DWR ring (51) from the stem guide (20) and replace it, taking care to lubricate it with synthetic grease.  <div style="border: 1px solid black; padding: 5px;"> <p><b>! NOTE!</b></p> <p><b>Before inserting the replacement I/DWR ring, clean the retaining slots with a cleaning solution.</b></p> </div>
47	Remove the O-ring (36) from the stem guide (20) and replace it, taking care to lubricate it with synthetic grease.  <div style="border: 1px solid black; padding: 5px;"> <p><b>! NOTE!</b></p> <p><b>Before inserting the replacement O-ring, clean the retaining slots with a cleaning solution.</b></p> </div>
48	Remove the O-rings (40, 41) from the stem guide (20) and replace them, taking care to lubricate them with synthetic grease.  <div style="border: 1px solid black; padding: 5px;"> <p><b>! NOTE!</b></p> <p><b>Before inserting the replacement O-rings, clean the retaining slots with a cleaning solution.</b></p> </div>

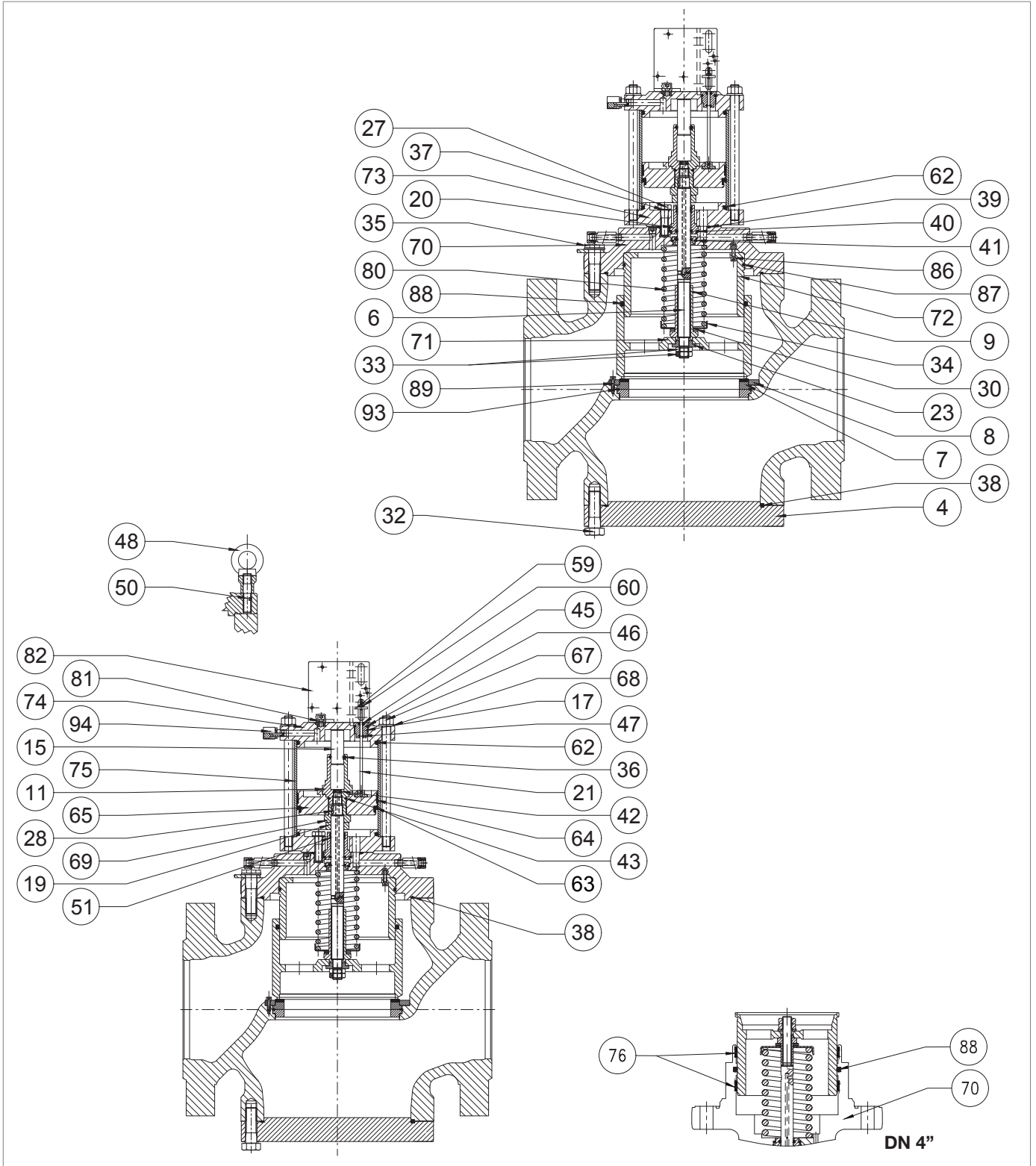



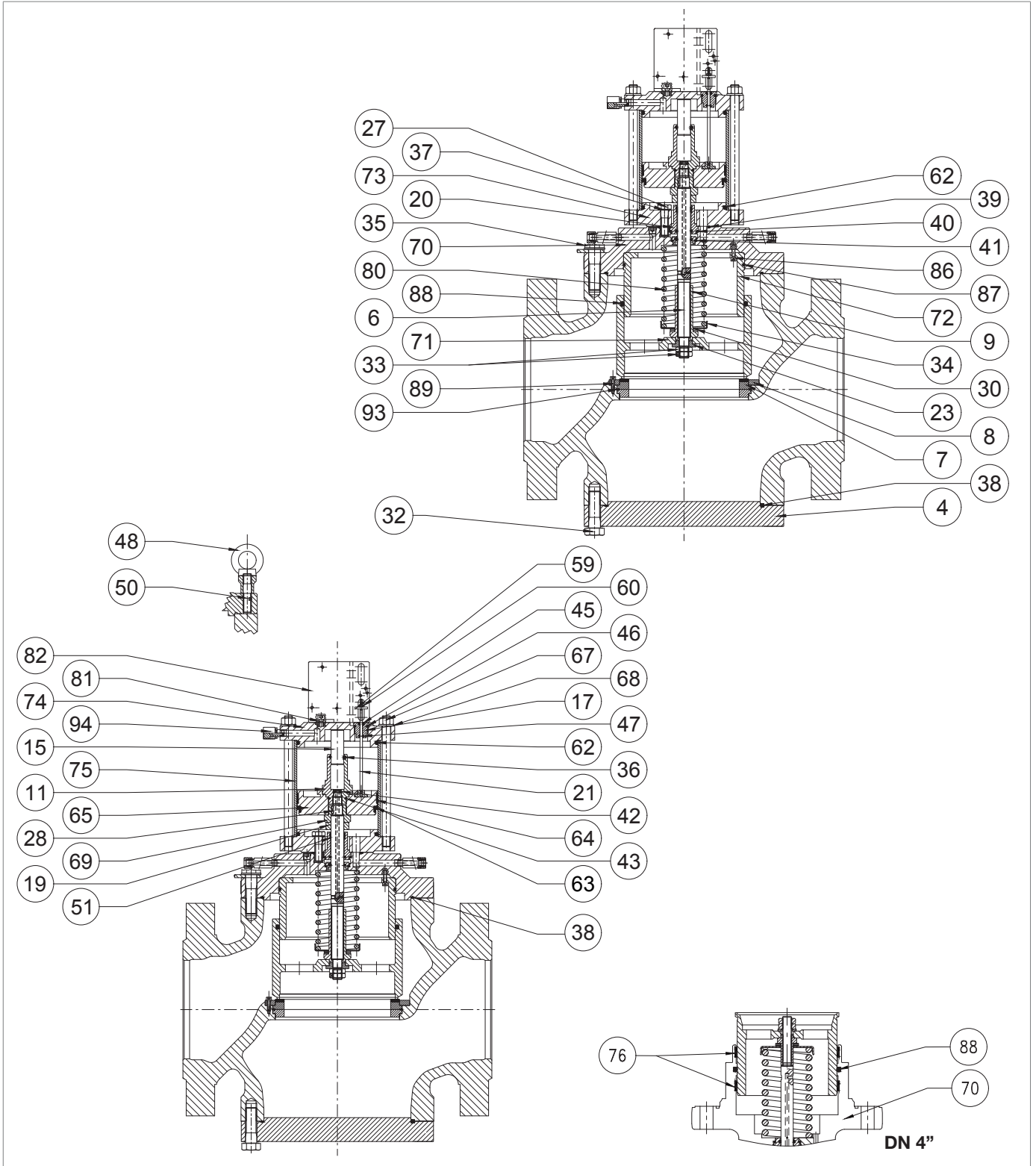

HBC 975 Slam-shut valve

Step	Action
49	Remove the O-ring (42) from the stem (6) and replace it, taking care to lubricate it with synthetic grease. <b>NOTE!</b> <b>Before inserting the replacement O-ring, clean the retaining slots with a cleaning solution.</b>
50	<b>APPLICABLE FOR DN 6"- 12" ONLY</b> Undo and remove the screws (86).
51	<b>APPLICABLE FOR DN 6"- 12" ONLY</b> Take out the plug guide (72). <b>NOTE!</b> <b>In this step, tighten some M6x50 screws into the threaded holes of the plug guide; screw them in for vertical removal so that the plug guide remains always aligned.</b>
52	Remove the screws M6x50.
53	<b>APPLICABLE FOR DN 6"- 12" ONLY</b> Remove the O-ring (87) from the plug guide (72) and replace it, taking care to lubricate it with synthetic grease. <b>NOTE!</b> <b>Before inserting the replacement O-ring, clean the retaining slots with a cleaning solution.</b>
54	<b>APPLICABLE FOR DN 6"- 12" ONLY</b> Put the plug guide (72) in place.
55	<b>APPLICABLE FOR DN 6"- 12" ONLY</b> Insert and fix the screws (86) according to the following tightening torques: <ul style="list-style-type: none"> <li>• DN 6" &gt; tab. 9.51;</li> <li>• DN 8" &gt; tab. 9.52;</li> <li>• DN 10" &gt; tab. 9.53;</li> <li>• DN 12" &gt; tab. 9.54.</li> </ul> <b>NOTE!</b> <b>Tighten the screws according to the cross diagram in paragraph 9.4.2.2.</b>
56	Insert the stem (6) together with the key (28) in the stem guide (20). <b>NOTE!</b> <b>Lubricate the rod surface with silicone grease; make sure that the key (28) is in the correct position in the stem (6).</b>
57	Insert the stem guide (20) together with the stem (6) into the plug guide (70).
58	Fit the flange (73). <b>NOTE!</b> <b>Match the chamber pressurisation hole with the plug guide hole (70)</b>







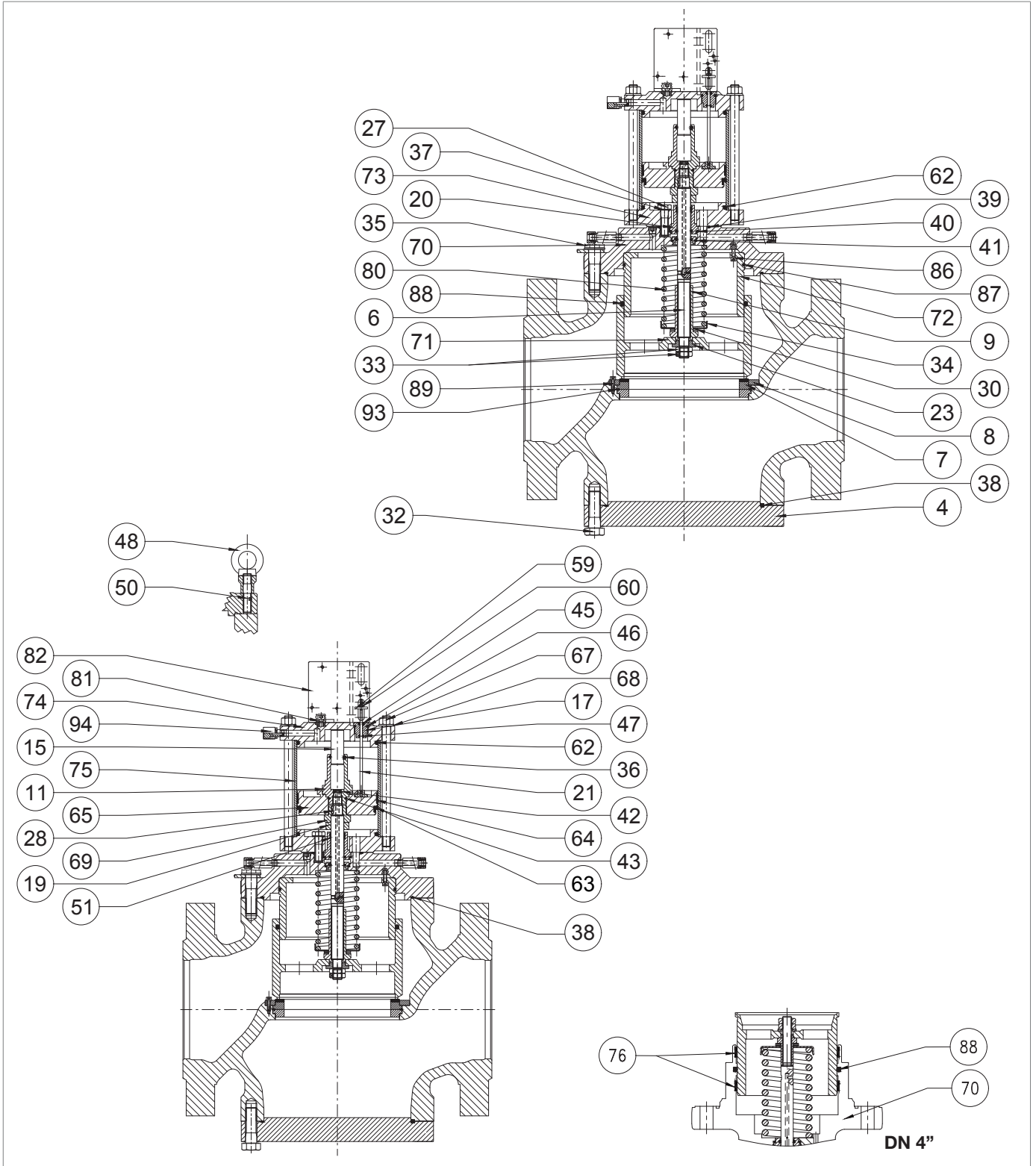

HBC 975 Slam-shut valve

Step	Action
59	Insert and fix the screws (27) together with the washers (37) according to the following tightening torques: <ul style="list-style-type: none"> <li>• DN 4" &gt; tab. 9.50;</li> <li>• DN 6" &gt; tab. 9.51;</li> <li>• DN 8" &gt; tab. 9.52;</li> <li>• DN 10" &gt; tab. 9.53;</li> <li>• DN 12" &gt; tab. 9.54.</li> </ul> <div style="border: 1px solid black; padding: 5px;">  <b>NOTE!</b>  <b>Tighten the screws according to the cross diagram in paragraph 9.4.2.2.</b> </div>
60	<b>APPLICABLE TO DN 6"-12" ONLY</b> Insert the spacer (19).
61	Insert the nut (69). <div style="border: 1px solid black; padding: 5px;">  <b>NOTE!</b>  <b>Make sure that the key (28) is present and correctly positioned in the stem (6).</b> </div>
62	Fit the piston (65).
63	Keeping the nut (69) in position, insert and fix the balancing piston guide (11) according to the tightening torques: <ul style="list-style-type: none"> <li>• DN 4" &gt; tab. 9.50;</li> <li>• DN 6" &gt; tab. 9.51;</li> <li>• DN 8" &gt; tab. 9.52;</li> <li>• DN 10" &gt; tab. 9.53;</li> <li>• DN 12" &gt; tab. 9.54.</li> </ul>
64	Fit the spring (80) together with the spring support (34) and the radial bearing (30).
65	Keeping the nut (69) in position, insert and fix the nut (9) according to the following tightening torques: <ul style="list-style-type: none"> <li>• DN 4" &gt; tab. 9.50;</li> <li>• DN 6" &gt; tab. 9.51;</li> <li>• DN 8" &gt; tab. 9.52;</li> <li>• DN 10" &gt; tab. 9.53;</li> <li>• DN 12" &gt; tab. 9.54.</li> </ul>
66	Fit the plug (71).
67	Insert and fix the nuts (33) together with the washers (23) according to the following tightening torques: <ul style="list-style-type: none"> <li>• DN 4" &gt; tab. 9.50;</li> <li>• DN 6" &gt; tab. 9.51;</li> <li>• DN 8" &gt; tab. 9.52;</li> <li>• DN 10" &gt; tab. 9.53;</li> <li>• DN 12" &gt; tab. 9.54.</li> </ul> <div style="border: 1px solid black; padding: 5px;">  <b>NOTE!</b>  <b>Before fitting the external nut (33), apply some thread locking glue.</b> </div>
68	Fit the plating (75). <div style="border: 1px solid black; padding: 5px;">  <b>NOTE!</b>  <b>Before refitting the plating (75), clean and lubricate the internal surface with silicone grease.</b> </div>
69	Fit the upper flange (74). <div style="border: 1px solid black; padding: 5px;">  <b>NOTE!</b>  <b>The stroke indicator hole is in front of the HB/97 built-in slam-shut valve.</b> </div>



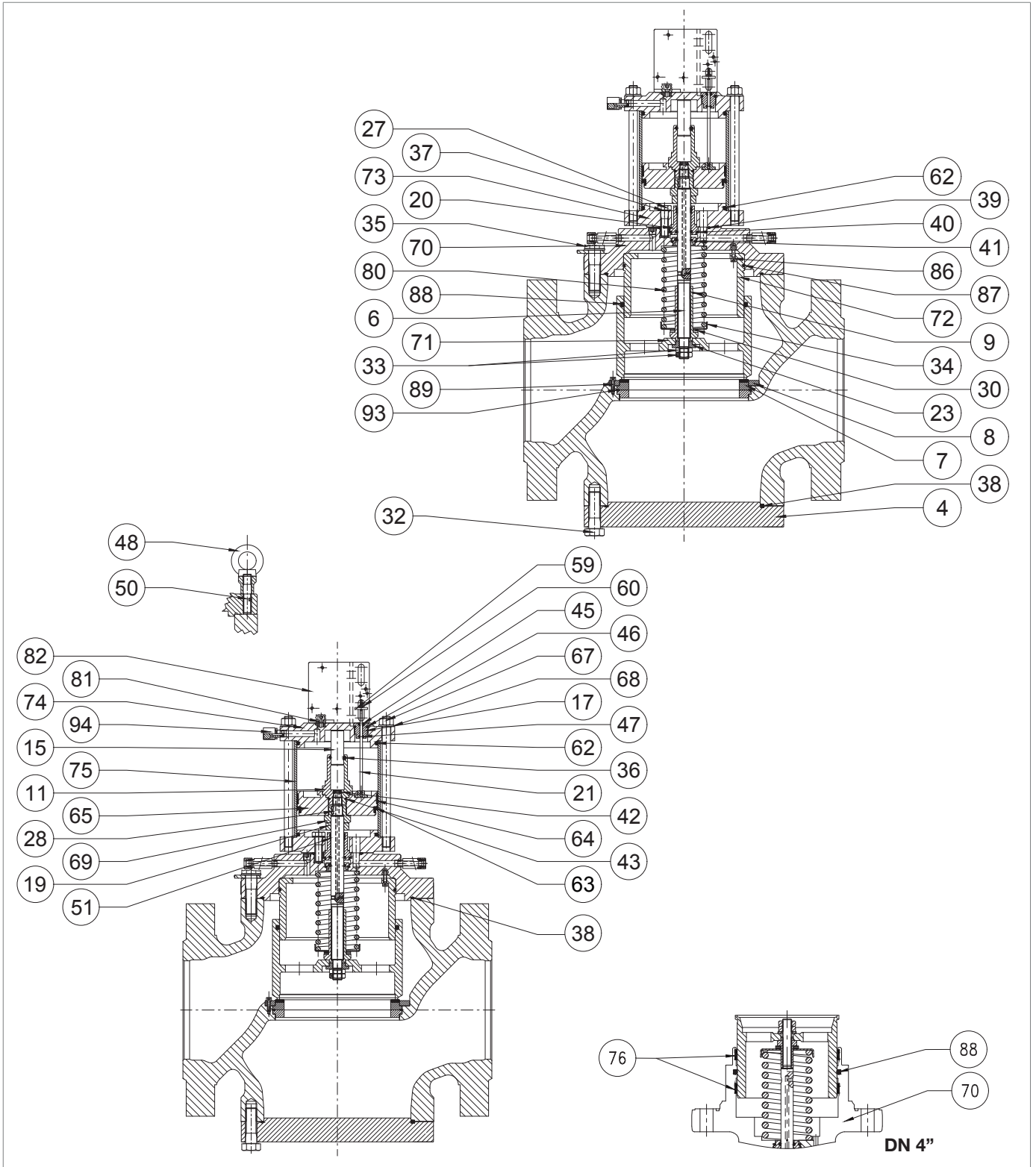

HBC 975 Slam-shut valve

Step	Action
70	Insert and fix the nuts (67) according to the following tightening torques: <ul style="list-style-type: none"> <li>• DN 4" &gt; tab. 9.50;</li> <li>• DN 6" &gt; tab. 9.51;</li> <li>• DN 8" &gt; tab. 9.52;</li> <li>• DN 10" &gt; tab. 9.53;</li> <li>• DN 12" &gt; tab. 9.54.</li> </ul>
71	Remove the O-ring (38) from the flange (70) and replace it, taking care to lubricate it with synthetic grease. <div style="border: 1px solid black; padding: 5px; margin-top: 10px;">  <b>NOTE!</b>  <b>Before inserting the replacement O-ring, clean the retaining slots with a cleaning solution.</b> </div>
72	HB/97 put the built-in slam-shut valve back in place. <div style="border: 1px solid black; padding: 5px; margin-top: 10px;">  <b>NOTE!</b>  <b>If the slam-shut valve is in the inverted position, support it during this step to prevent any falls.</b> </div>
73	Insert and fix the screws (35). <div style="border: 1px solid black; padding: 5px; margin-top: 10px;">  <b>NOTE!</b>  <b>Tighten the screws according to the cross diagram in paragraph 9.4.2.2.</b> </div>
74	Insert the indicator rod (21). <div style="border: 1px solid black; padding: 5px; margin-top: 10px;">  <b>NOTE!</b>  <b>The rod must be fitted into the slot in the piston (65).</b> </div>
75	Insert and fix the screws (17).
76	Put the bracket (82) in place.
77	Insert and fix the screws (81) according to the following tightening torques: <ul style="list-style-type: none"> <li>• DN 4" &gt; tab. 9.50;</li> <li>• DN 6" &gt; tab. 9.51;</li> <li>• DN 8" &gt; tab. 9.52;</li> <li>• DN 10" &gt; tab. 9.53;</li> <li>• DN 12" &gt; tab. 9.54.</li> </ul> <div style="border: 1px solid black; padding: 5px; margin-top: 10px;">  <b>NOTE!</b>  <b>Tighten the screws according to the cross diagram in paragraph 9.4.2.2.</b> </div>
78	Fit and set the indicator washer (59) to "0".
79	Insert and fix the screws (60).
80	Undo and remove the screws (32).
81	Remove the blind flange (4) together with the O-ring (38). <div style="border: 1px solid black; padding: 5px; margin-top: 10px;">  <b>NOTE!</b>  <b>In this step, support the SB/97 valve to prevent any falls.</b> </div>
82	Replace the O-ring (38) and lubricate it with synthetic grease. <div style="border: 1px solid black; padding: 5px; margin-top: 10px;">  <b>NOTE!</b>  <b>Before inserting the replacement O-ring, clean the retaining slots with a cleaning solution</b> </div>



HBC 975 Slam-shut valve



Step	Action
83	Refit the flange (4). <div style="border: 1px solid black; padding: 2px;">  <b>NOTE!</b> </div> <b>In this step, support the SB/97 valve to prevent any falls.</b>
84	Insert and fix the screws (32) according to the following tightening torques: <ul style="list-style-type: none"> <li>• DN 4" &gt; tab. 9.50;</li> <li>• DN 6" &gt; tab. 9.51;</li> <li>• DN 8" &gt; tab. 9.52;</li> <li>• DN 10" &gt; tab. 9.53;</li> <li>• DN 12" &gt; tab. 9.54.</li> </ul> <div style="border: 1px solid black; padding: 2px;">  <b>NOTE!</b> </div> <b>Tighten the screws according to the cross diagram in paragraph 9.4.2.2.</b>
85	<div style="border: 1px solid black; padding: 2px;">  <b>NOTE!</b> </div> <b>To reconnect the LINE OFF 2.0, refer to paragraph 9.4.7. tab. 9.71.</b>

Tab. 1.62.

 **WARNING!**  
**Ensure that all parts have been fitted correctly.**

**1.4.5 - LINE OFF 2.0 MAINTENANCE PROCEDURE**

**1.4.5.1 - HP2/2 BYPASS DEVICE**

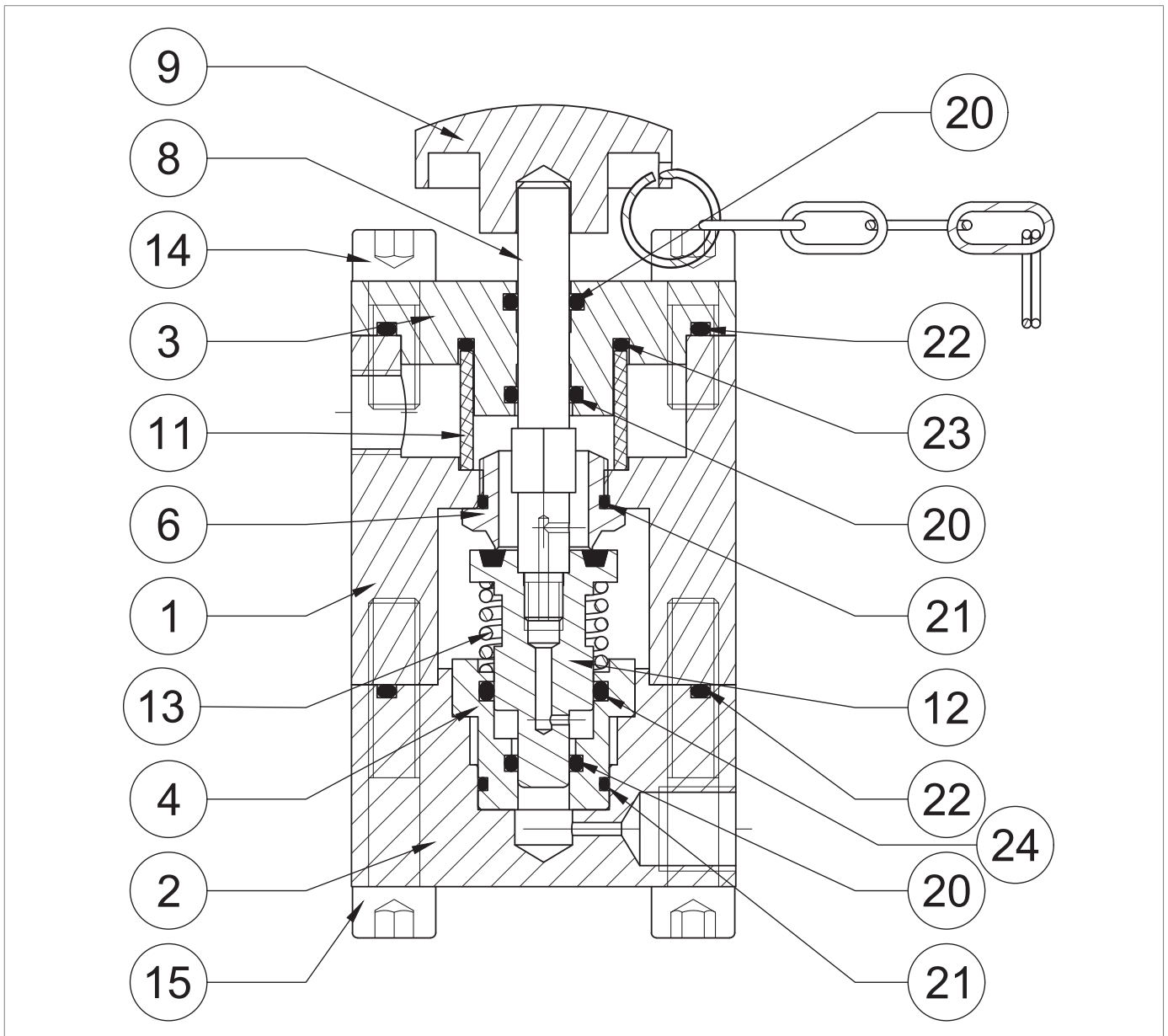
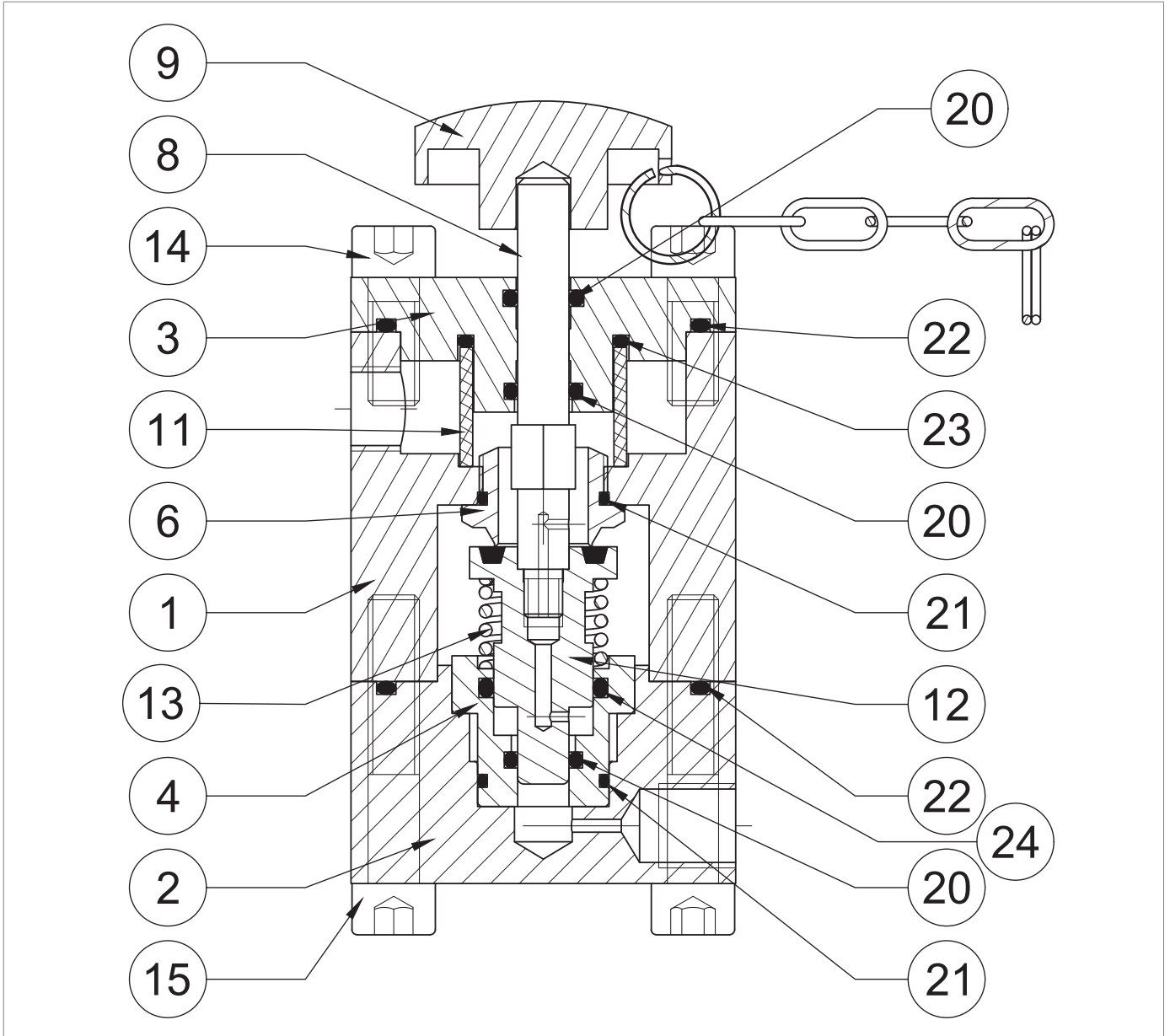





Fig. 1.23. HP2/2 bypass device

Step	Action
1	Remove the knob (9).
2	Undo and remove the screws (15).
3	Remove the lid (2) together with the bush (4), spring (13), plug (12) and stem (8).
4	Remove the bush (4), together with the spring (13), plug (12), stem (8) from the lid (2).
5	Remove the O-ring (22) from the lid (2) and replace it, taking care to lubricate it with synthetic grease. <b>NOTE!</b> <b>Before inserting the replacement O-ring, clean the retaining slots with a cleaning solution.</b>
6	Fit the plug (12) together with the stem (8).
7	Separate the stem (8) from the plug (12).
8	Insert the plug (12).
9	Remove the O-rings (20, 21, 24) from the bush (4) and replace them, taking care to lubricate them with synthetic grease. <b>NOTE!</b> <b>Before inserting the replacement O-rings, clean the retaining slots with a cleaning solution.</b>
10	Undo and remove the screws (6). <b>NOTE!</b> <b>Attention do not to ruin the seat profile during this step.</b>
11	Remove the O-ring (21) from the seat (6) and replace it, taking care to lubricate it with synthetic grease. <b>NOTE!</b> <b>Before inserting the replacement O-ring, clean the retaining slots with a cleaning solution.</b>
12	Undo and remove the screws (14).
13	Remove the flange (3).
14	Remove the O-rings (22, 23) from the flange (3) and replace them, taking care to lubricate them with synthetic grease. <b>NOTE!</b> <b>Before inserting the replacement O-rings, clean the retaining slots with a cleaning solution.</b>
15	Remove the O-rings (20) from the flange (3) and replace them, taking care to lubricate them with synthetic grease. <b>NOTE!</b> <b>Before inserting the replacement O-rings, clean the retaining slots with a cleaning solution.</b>
16	Remove and replace the filter (11).
17	Put the flange (3) back in place.
18	Insert and fix the screws (14) according to the following tightening torque: • HP2/2 > tab. 9.55. <b>NOTE!</b> <b>Tighten the screws according to the cross diagram in paragraph 9.4.2.2.</b>



HP2/2 bypass device

Step	Action
19	Fit and fix the seat (6) in the body (1). <div style="border: 1px solid blue; padding: 5px;">  <b>NOTE!</b>  <b>Care must be taken not to ruin the seat profile during this step.</b> </div>
20	Fit the bush (4) in the lid (2).
21	Screw the stem (8) into the plug (12). <div style="border: 1px solid blue; padding: 5px;">  <b>NOTE!</b>  <b>Before fitting the stem (8), apply thread locking glue.</b> </div>
22	Fit the spring (13).
23	Fit the plug (12) together with the stem (8) into the bush (4).
24	Fit the lid (2) together with the bush (4).
25	Insert and fix the screws (15) according to the following tightening torque: <ul style="list-style-type: none"> <li>• HP2/2 &gt; tab. 9.55.</li> </ul> <div style="border: 1px solid blue; padding: 5px;">  <b>NOTE!</b>  <b>Tighten the screws according to the cross diagram in paragraph 9.4.2.2.</b> </div>

Tab. 1.63.

 **WARNING!**

**Ensure that all parts have been fitted correctly.**

**1.4.5.2 - PRESSURE REGULATOR R44/SS**

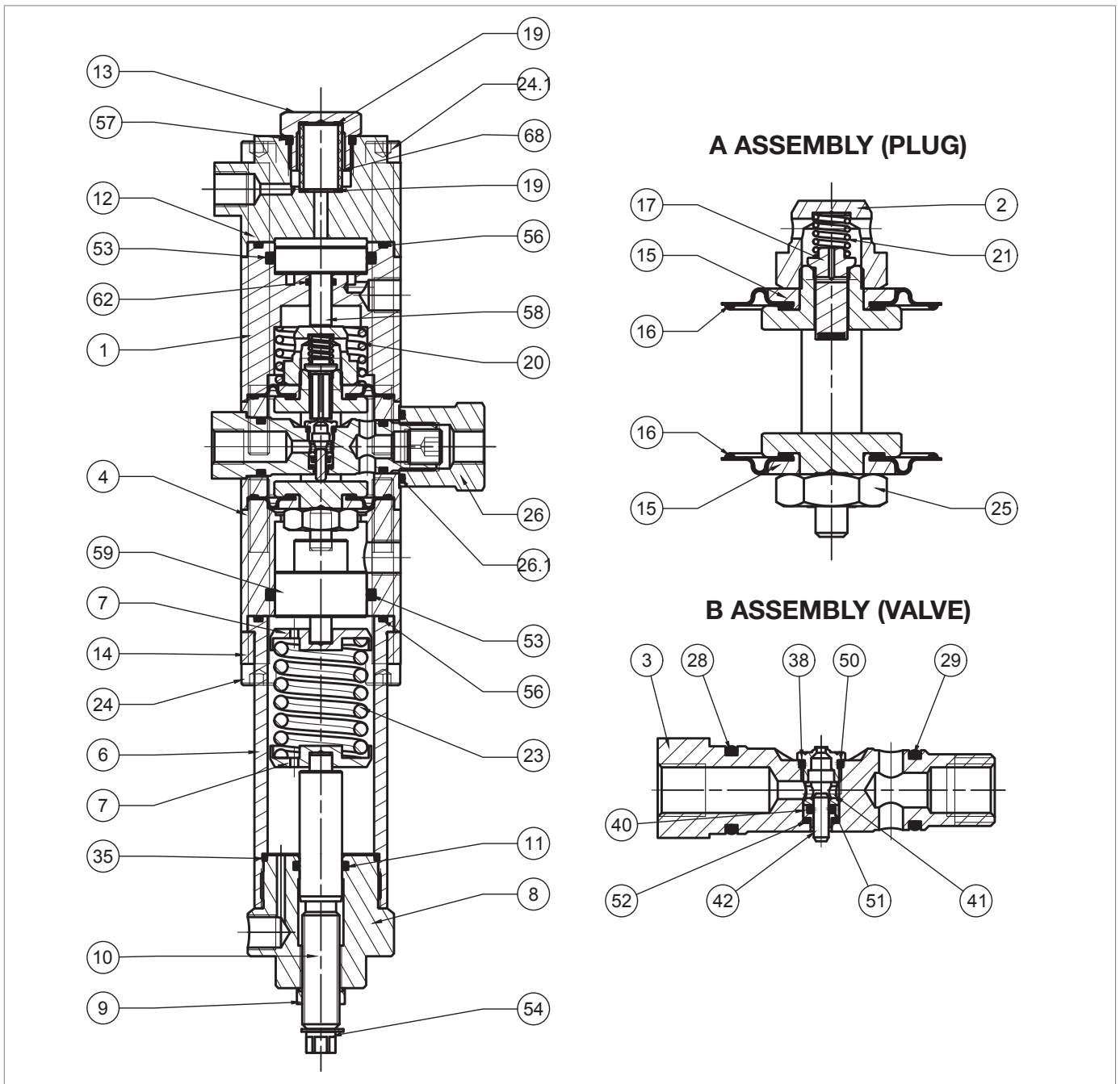





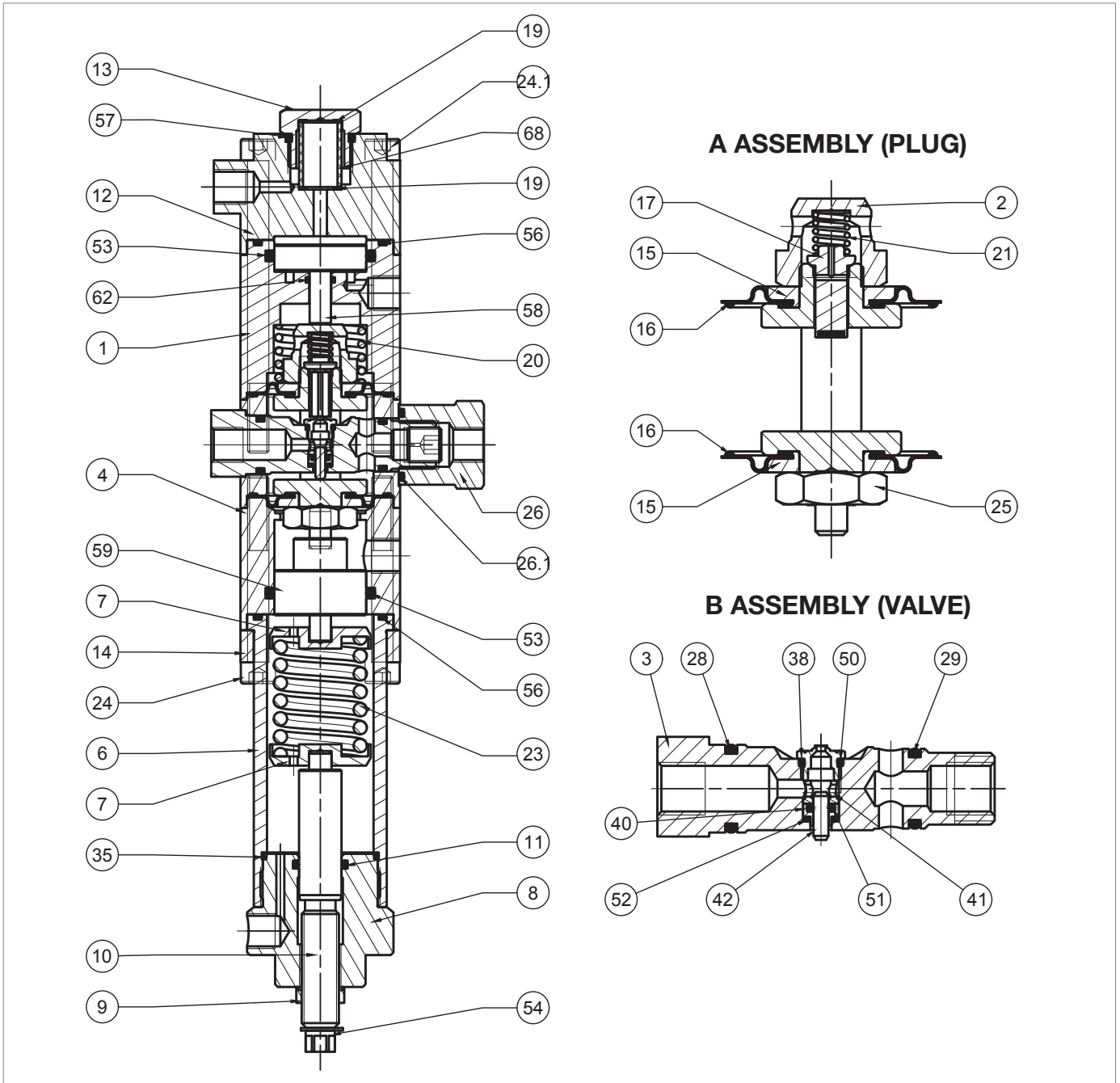

Fig. 1.24. Pressure regulator R44/SS

Step	Action
1	Remove the seeger ring (54).
2	Unscrew the nut (9).
3	Completely release the spring (23) by turning the adjustment screw (10)
4	Unscrew and remove the cap (8).
5	Remove the spring (23) and the spring supports (7).
6	Remove the screw (10) from the cap (8) clockwise, from the inside to the outside.
7	Remove the O-ring (11) from the cap (8) and replace it, taking care to lubricate it with synthetic grease. <div style="border: 1px solid black; padding: 5px; margin-top: 5px;">  <b>NOTE!</b>  <b>Before inserting the replacement O-ring, clean the retaining slots with a cleaning solution.</b> </div>
8	Insert the screw (10) into the cap (8) anti-clockwise, from the outside to the inside.
9	Insert and fix the nut (9).
10	Fit the seeger ring (54).
11	Undo and remove the screws (24).
12	Remove the bracket (14).
13	Remove the sleeve (6).
14	Remove the O-ring (56) from the sleeve (6) and replace it, taking care to lubricate it with synthetic grease. <div style="border: 1px solid black; padding: 5px; margin-top: 5px;">  <b>NOTE!</b>  <b>Before inserting the replacement O-ring, clean the retaining slots with a cleaning solution.</b> </div>
15	Remove the O-ring (35) from the sleeve (6) and replace it, taking care to lubricate it with synthetic grease. <div style="border: 1px solid black; padding: 5px; margin-top: 5px;">  <b>NOTE!</b>  <b>Before inserting the replacement O-ring, clean the retaining slots with a cleaning solution.</b> </div>
16	Remove the spacer (4).
17	Take out the piston (59).
18	Remove the O-ring (53) from the spacer (4) and replace it, taking care to lubricate it with synthetic grease. <div style="border: 1px solid black; padding: 5px; margin-top: 5px;">  <b>NOTE!</b>  <b>Before inserting the replacement O-ring, clean the retaining slots with a cleaning solution.</b> </div>
19	Unscrew and remove the cap (13).
20	Remove the O-ring (57) from the cap (13) and replace it, taking care to lubricate it with synthetic grease. <div style="border: 1px solid black; padding: 5px; margin-top: 5px;">  <b>NOTE!</b>  <b>Before inserting the replacement O-ring, clean the retaining slots with a cleaning solution.</b> </div>
21	Remove and replace the filter (68).
22	Remove the gaskets (19).
23	Undo and remove the screws (24.1).
24	Remove the lid (12).
25	Remove the lid (1).
26	Take out the piston (58).







Pressure regulator R44/SS

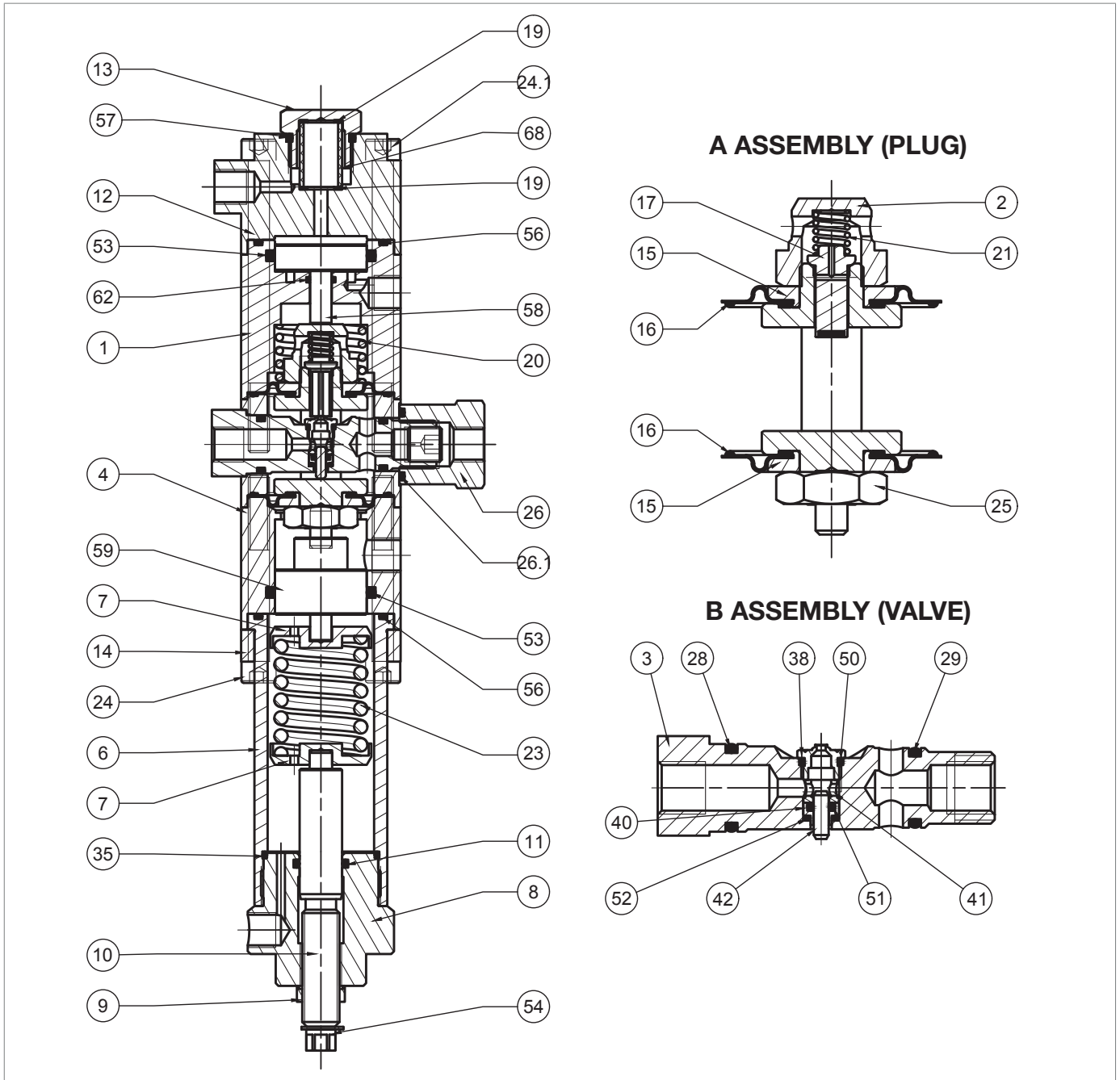

Step	Action
27	Remove the O-ring (56) from the lid (1) and replace it, taking care to lubricate it with synthetic grease. <b>NOTE!</b> <b>Before inserting the replacement O-ring, clean the retaining slots with a cleaning solution.</b>
28	Remove the O-rings (53, 62) from the lid (1) and replace it, taking care to lubricate them with synthetic grease. <b>NOTE!</b> <b>Before inserting the replacement O-rings, clean the retaining slots with a cleaning solution.</b>
29	Remove the spring (20).
30	Unscrew the nut (26).
31	Remove the O-ring (26.1) from the nut (26) and replace it, taking care to lubricate it with synthetic grease. <b>NOTE!</b> <b>Before inserting the replacement O-ring, clean the retaining slots with a cleaning solution.</b>
32	Remove assembly "B" (valve).
33	Unscrew the valve seat (38). <b>NOTE!</b> <b>Take care not to damage the surfaces.</b>
34	Remove the O-ring (50) from the valve seat (38) and replace it, taking care to lubricate it with synthetic grease. <b>NOTE!</b> <b>Before inserting the replacement O-ring, clean the retaining slots with a cleaning solution.</b>
35	Remove the bush (41).
36	Remove the balancing piston (42).
37	Take out the piston guide (40).
38	Remove the O-ring (51) from the piston guide (40) and replace it, taking care to lubricate it with synthetic grease. <b>NOTE!</b> <b>Before inserting the replacement O-ring, clean the retaining slots with a cleaning solution.</b>
39	Remove the O-ring (52) from the valve seat (3) and replace it, taking care to lubricate it with synthetic grease. <b>NOTE!</b> <b>Before inserting the replacement O-ring, clean the retaining slots with a cleaning solution.</b>
40	Remove the O-rings (28, 29) from the valve seat (3) and replace them, taking care to lubricate them with synthetic grease. <b>NOTE!</b> <b>Before inserting the replacement O-rings, clean the retaining slots with a cleaning solution.</b>
41	Fit the piston guide (40) and balancing piston (42).
42	Insert the bush (41) into the pilot seat (3) so that the wider stop rests on the O-ring (51).



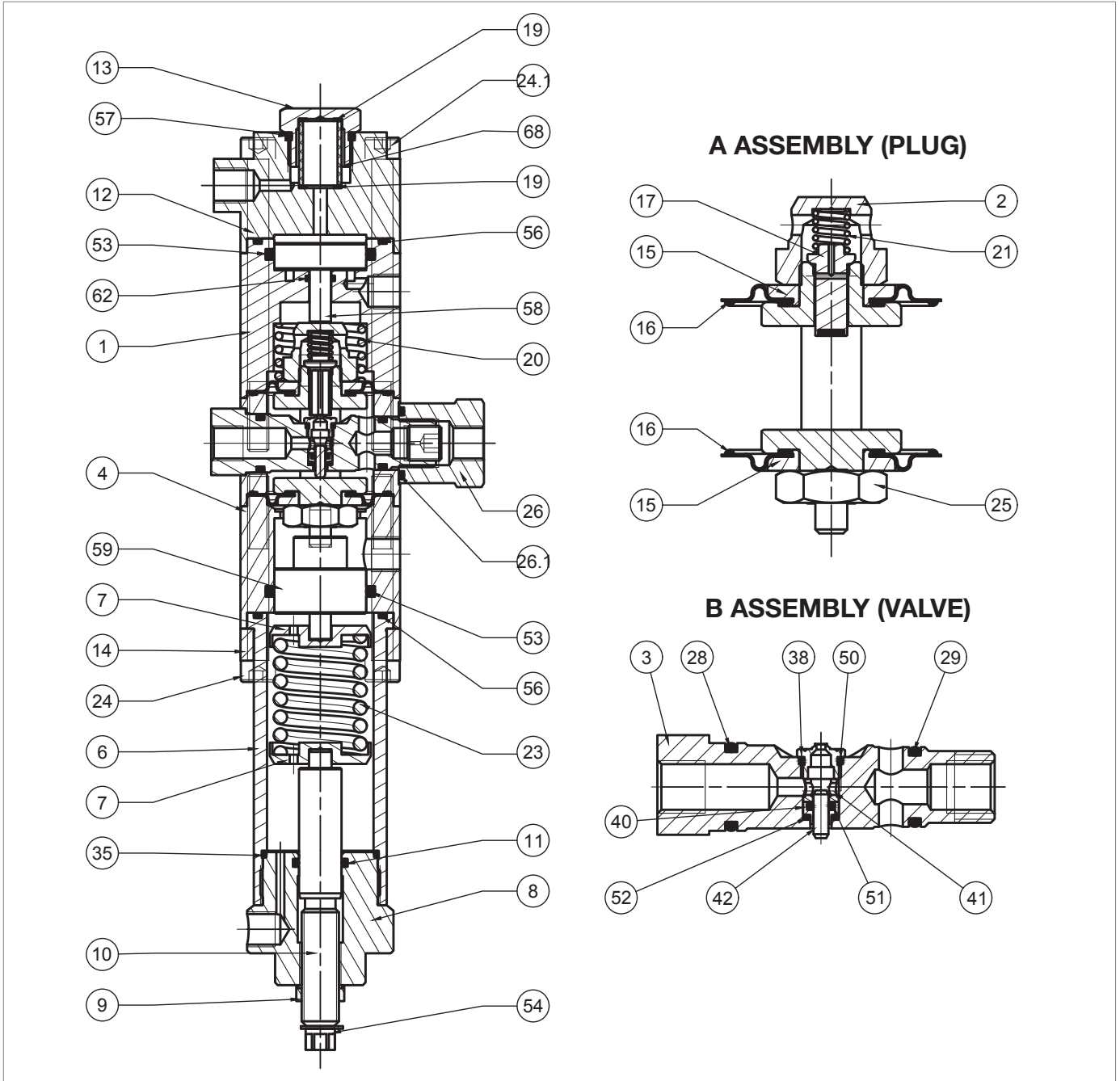

Pressure regulator R44/SS

Step	Action
43	Insert and fix the valve seat (38). <div style="border: 1px solid black; padding: 5px;">  <b>NOTE!</b>  <b>Take care not to damage the valve seat profile (38) and the O-ring (50).</b> </div>
44	Remove assembly “A” (plug) from the valve body (4).
45	Unscrew and remove the pilot nut (2).
46	Remove the spring (21).
47	Remove and replace the plug (17).
48	Remove the upper protection disc (15)
49	Remove and replace the upper diaphragm (16), taking care to lubricate the lanyards with synthetic grease. <div style="border: 1px solid black; padding: 5px;">  <b>NOTE!</b>  <b>Before inserting the replacement diaphragm, clean the retaining slots with a cleaning solution.</b> </div>
50	Unscrew and remove the nut (25).
51	Remove the lower protection disc (15).
52	Remove and replace the lower diaphragm (16), taking care to lubricate the lanyards with synthetic grease. <div style="border: 1px solid black; padding: 5px;">  <b>NOTE!</b>  <b>Before inserting the replacement diaphragm, clean the retaining slots with a cleaning solution.</b> </div>
53	Fit the lower protection disc (15).
54	Insert and fix the screws (25) according to the following tightening torque: <ul style="list-style-type: none"> <li>• R44/SS &gt; tab. 9.56.</li> </ul>
55	Fit the upper protection disc (15).
56	Fit the plug (17).
57	Fit the spring (21).
58	Insert and fix the pilot nut (2) according to the following tightening torque: <ul style="list-style-type: none"> <li>• R44/SS &gt; tab. 9.56.</li> </ul>
59	Insert assembly “A” (plug) from top to bottom into the valve body (4). <div style="border: 1px solid black; padding: 5px;">  <b>NOTE!</b> <ul style="list-style-type: none"> <li>• <b>Take care not to damage the diaphragms (16) during this step;</b></li> <li>• <b>The marking on the lower section of the headframe must be parallel to the axis of the hole for inserting the seat (3) into the valve body (4).</b></li> </ul> </div>
60	Insert assembly “B” (valve) into the valve body (4). <div style="border: 1px solid black; padding: 5px;">  <b>NOTE!</b> <ul style="list-style-type: none"> <li>• <b>Insert the assembly with the valve seat (38) facing upwards;</b></li> <li>• <b>Take care not to damage the O-rings (28, 29) and the valve seat (38).</b></li> </ul> </div>
61	Insert and fix the nut (26) according to the following tightening torque: <ul style="list-style-type: none"> <li>• R44/SS &gt; tab. 9.56.</li> </ul>
62	Fit the spring (20).
63	Insert the piston (58) into the lid (1).
64	Fit the lids (1 and 12).



Pressure regulator R44/SS

Step	Action
65	Insert and fix the screws (24.1) according to the following tightening torque: <ul style="list-style-type: none"> <li>R44/SS &gt; tab. 9.56.</li> </ul> <div style="border: 1px solid blue; padding: 5px; margin-top: 5px;">  <b>NOTE!</b> </div> <p><b>Tighten the screws according to the cross diagram in paragraph 9.4.2.2.</b></p>
66	Fit the gaskets (19) and the filter (68).
67	Fit and secure the nut (13)
68	Fit the piston (59) into the spacer (4).
69	Fit the sleeve (6).
70	Put the bracket (14) back in place.
71	Insert and fix the screws (24) according to the following tightening torque: <ul style="list-style-type: none"> <li>R44/SS &gt; tab. 9.56.</li> </ul> <div style="border: 1px solid blue; padding: 5px; margin-top: 5px;">  <b>NOTE!</b> </div> <p><b>Tighten the screws according to the cross diagram in paragraph 9.4.2.2.</b></p>
72	Insert the spring (23) together with the spring supports (7). <div style="border: 1px solid blue; padding: 5px; margin-top: 5px;">  <b>NOTE!</b> </div> <p><b>Make sure that the piston pin (59) is inside the spring support (7).</b></p>
73	Fit and secure the cap (8) to the sleeve (6).

Tab. 1.64.

 **WARNING!**

**Ensure that all parts have been fitted correctly.**

1.4.5.3 - AR100 LAMINATION VALVE

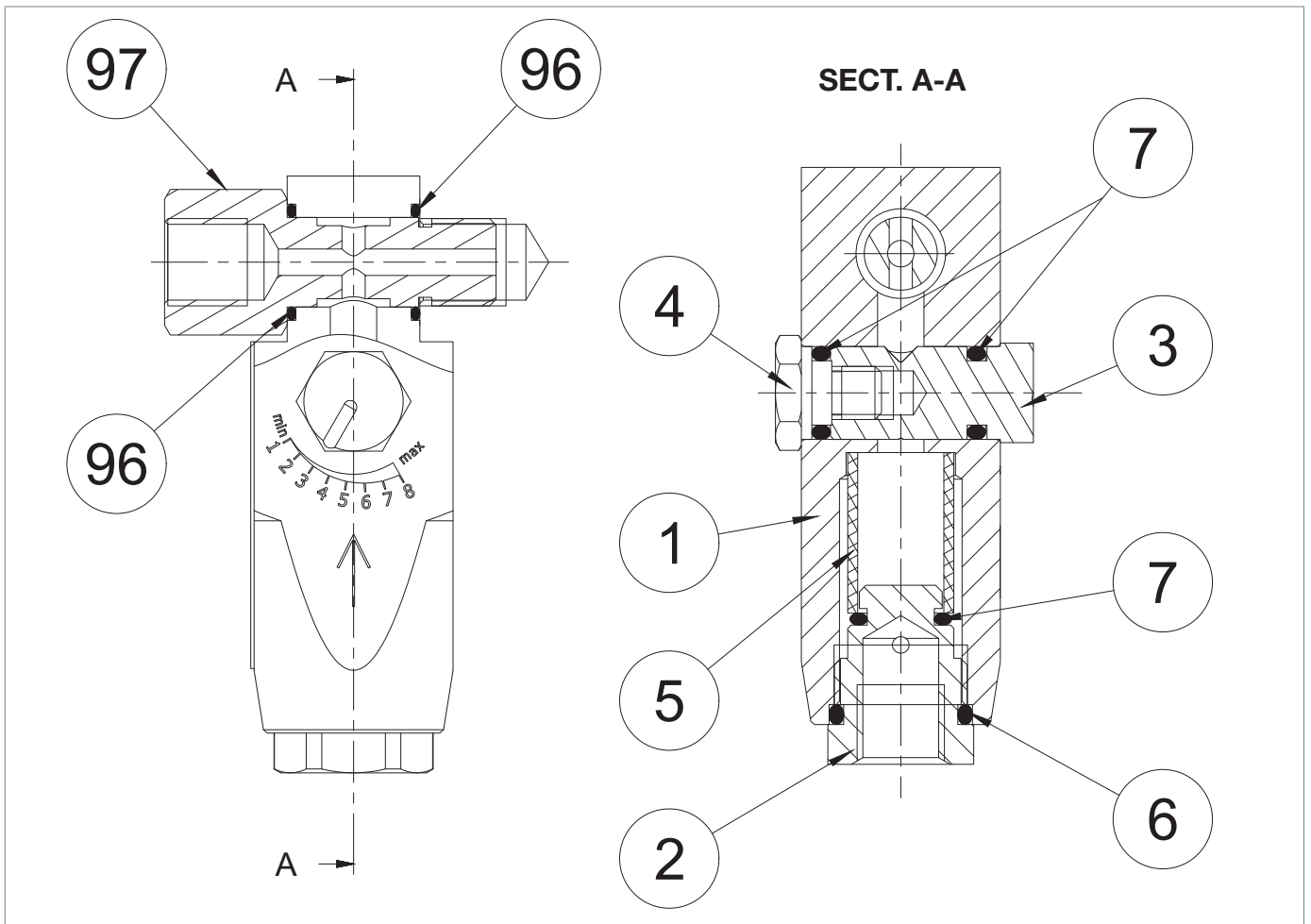







Fig. 1.25. AR100 lamination valve

Step	Action
1	Undo and remove the locking screw (97).
2	Remove the O-rings (96) from the AR100 lamination valve body (1) and replace them, taking care to lubricate them with synthetic grease.  <div style="border: 1px solid black; padding: 5px;">  <b>NOTE!</b>  <b>Before inserting the replacement O-rings, clean the retaining slots with a cleaning solution.</b> </div>
3	Undo and remove the locking screw (4).
4	Remove the O-rings (7) from the closing screw (4) and replace them, taking care to lubricate them with synthetic grease.  <div style="border: 1px solid black; padding: 5px;">  <b>NOTE!</b>  <b>Before inserting the replacement O-rings, clean the retaining slots with a cleaning solution.</b> </div>
5	Remove the adjustment screw (3).
6	Remove the O-rings (7) from the adjustment screw (3) and replace them, taking care to lubricate them with synthetic grease.  <div style="border: 1px solid black; padding: 5px;">  <b>NOTE!</b>  <b>Before inserting the replacement O-rings, clean the retaining slots with a cleaning solution.</b> </div>
7	Unscrew and remove the cap (2).
8	Remove the O-rings (6, 7) from the cap (2) and replace them, taking care to lubricate them with synthetic grease.  <div style="border: 1px solid black; padding: 5px;">  <b>NOTE!</b>  <b>Before inserting the replacement O-rings, clean the retaining slots with a cleaning solution.</b> </div>
9	Remove and replace the filter (5).
10	Fit and fix the cap (2) according to the following tightening torque: <ul style="list-style-type: none"> <li>AR100 &gt; tab. 9.57.</li> </ul> <div style="border: 1px solid black; padding: 5px;">  <b>NOTE!</b>  <b>Take care not to damage the O-rings (6, 7).</b> </div>
11	Insert the adjustment screw (3), taking care not to damage the O-ring (7).
12	Fit and fix the closing screw (4) according to the following tightening torque: <ul style="list-style-type: none"> <li>AR100 &gt; tab. 9.57.</li> </ul> <div style="border: 1px solid black; padding: 5px;">  <b>NOTE!</b>  <b>Take care not to damage the O-ring (7).</b> </div>
13	Insert the locking screw (97) with the valve ports in line with the AR100 lamination valve (1) body.

Tab. 1.65.

 **WARNING!**

**Ensure that all parts have been fitted correctly.**

1.4.5.4 - SAFETY VALVE VS/FI FOR LINE OFF 2.0

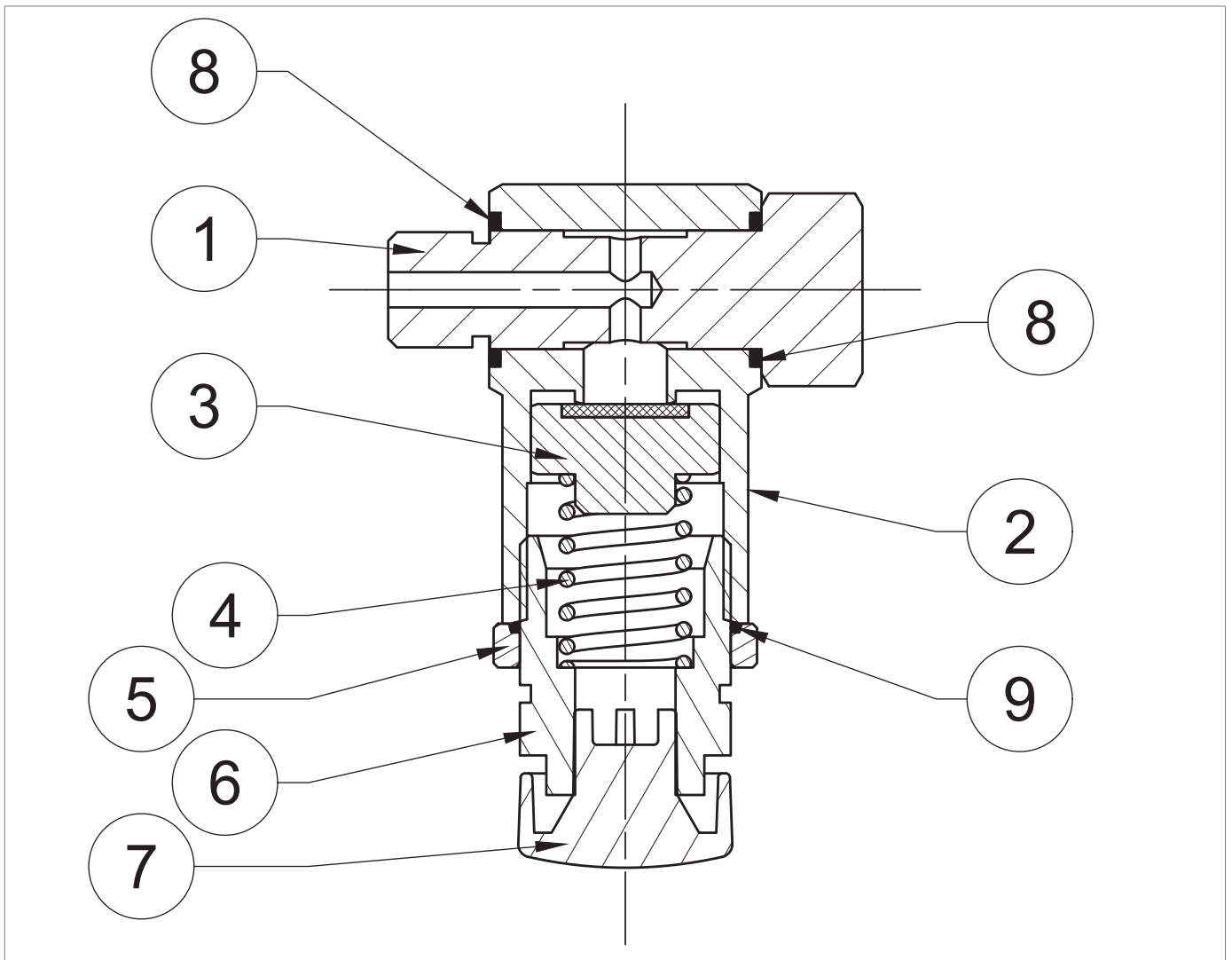



Fig. 1.26. Safety valve VS/FI for LINE OFF 2.0



Step	Action
1	Pull out the locking screw (1).
2	Remove the O-rings (8) from the body (2) and replace them, taking care to lubricate them with synthetic grease. <div style="border: 1px solid black; padding: 5px; margin-top: 5px;">  <b>NOTE!</b>  <b>Before inserting the replacement O-ring, clean the retaining slots with a cleaning solution.</b> </div>
3	Remove the vent plug (7) and make sure that it is not obstructed by any dirt.
4	Loosen the ring nut (5).
5	Unscrew and remove the cap (6).
6	Remove the O-ring (9) from the ring nut (5) and replace it, taking care to lubricate it with synthetic grease. <div style="border: 1px solid black; padding: 5px; margin-top: 5px;">  <b>NOTE!</b>  <b>Before inserting the replacement O-ring, clean the retaining slots with a cleaning solution.</b> </div>
7	Remove the spring (4).
8	Remove and replace the plug (3).
9	Insert the plug (3) and the spring (4).
10	Insert and screw in the cap (6).
11	Fit the vent cap (7).
12	Insert the locking screw (1).

Tab. 1.66.

 **WARNING!**

**Ensure that all parts have been fitted correctly.**

**1.4.6 - MAINTENANCE PROCEDURE FOR PRESSURE SWITCHES MODELS 102M/102MH - 105M/105MH**

**1.4.6.1 - PRESSURE SWITCH MOD. 102M/102MH**

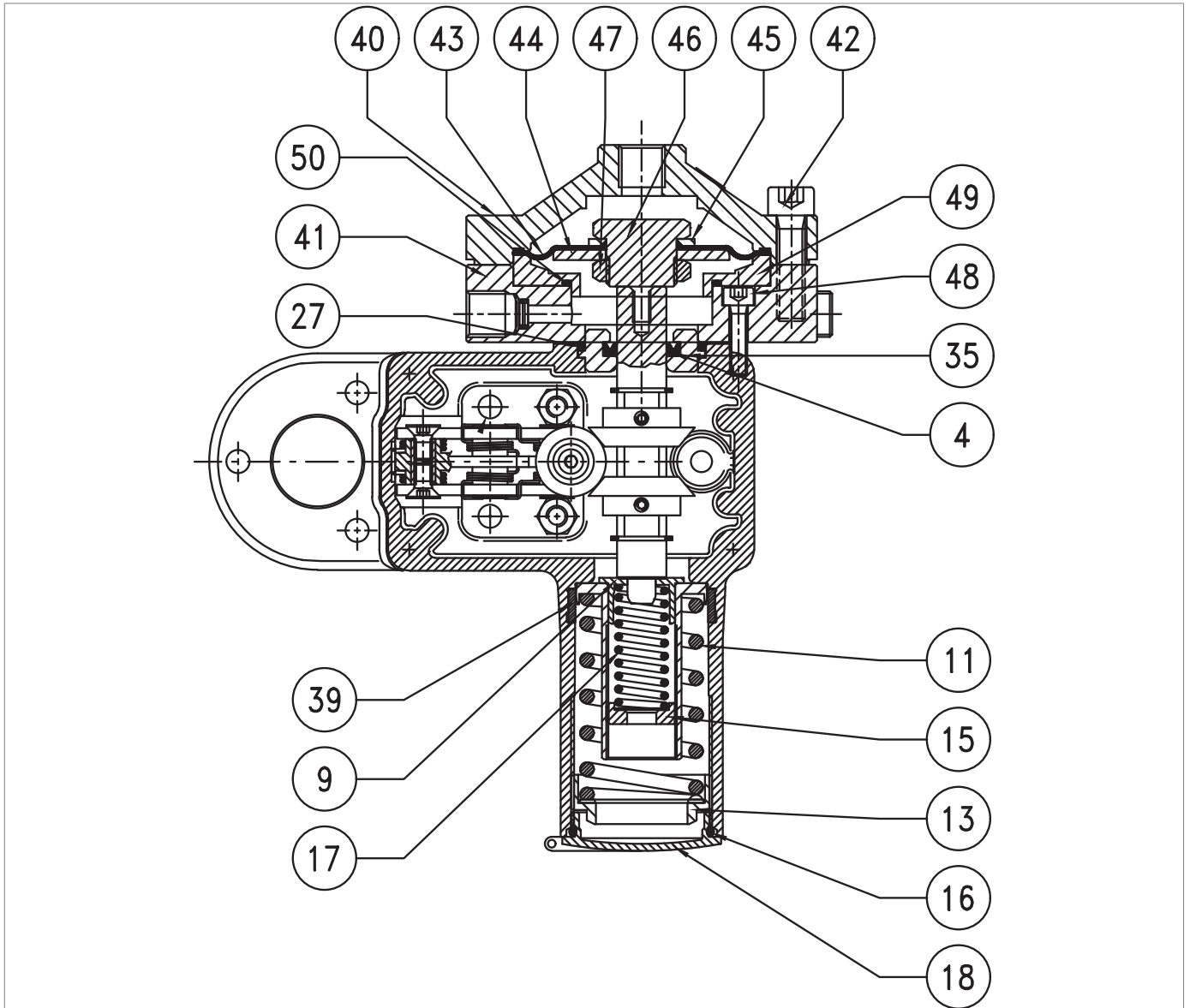
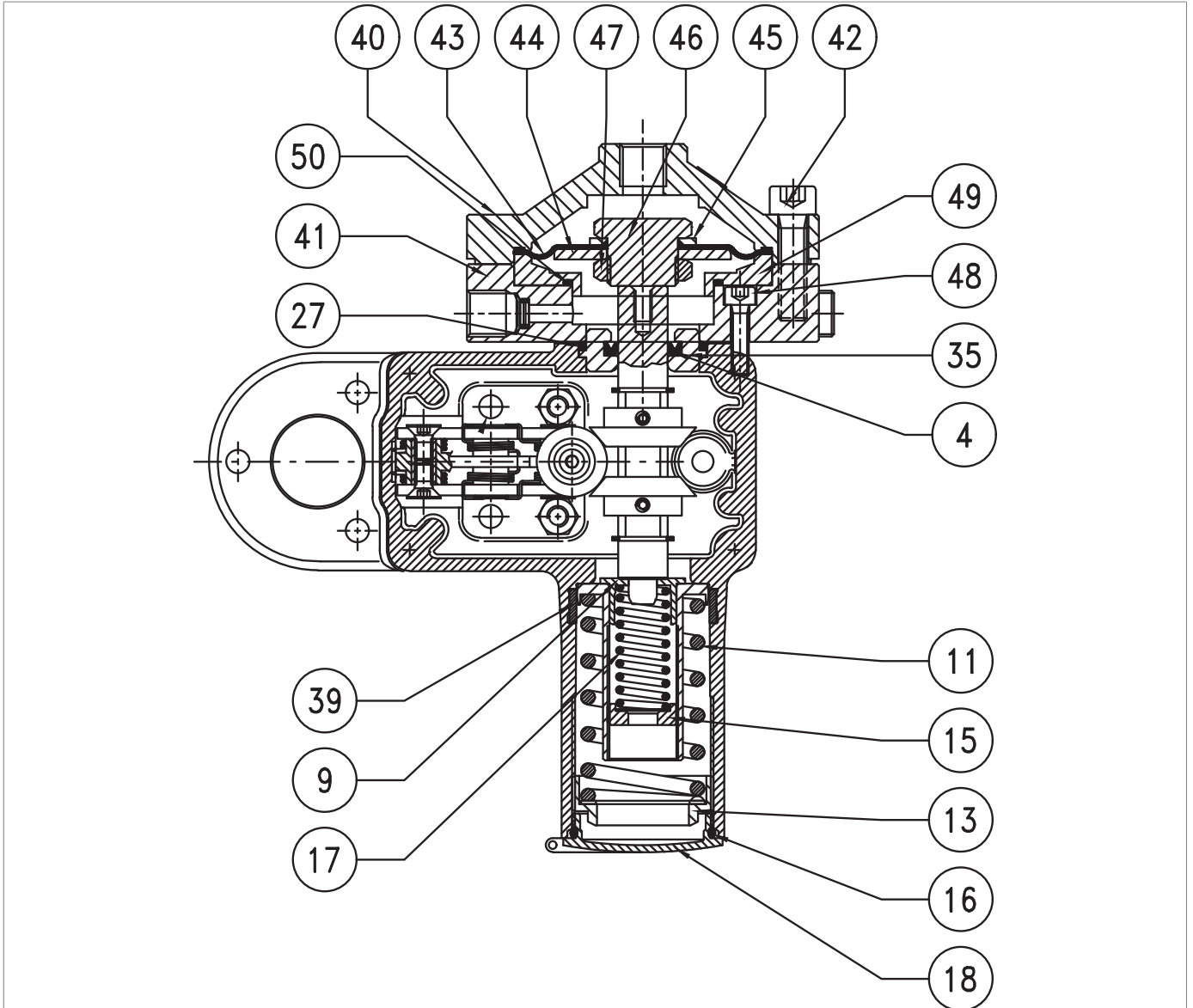

Fig. 1.27. Pressure switch Mod. 102M/102MH

Step	Action
1	Unscrew and remove the cap (18).
2	Remove the O-ring (16) from the lid (18) and replace it, taking care to lubricate it with synthetic grease. <b>NOTE!</b> <b>Before inserting the replacement O-ring, clean the retaining slots with a cleaning solution.</b>
3	Completely release the spring (11) by turning the ring nut (13).
4	Completely release the minimum pressure spring (17) by adjusting the ring nut (15). <b>NOTE!</b> <b>The minimum spring may not be present.</b>
5	Remove the ring nut (13), the spring (11) and the spring support (39).
6	Remove the I/DWR ring (39) from the pressure switch sleeve and replace it, taking care to lubricate it with synthetic grease. <b>NOTE!</b> <b>Before inserting the replacement I/DWR ring, clean the retaining slots with a cleaning solution.</b>
7	Undo and remove the screws (42).
8	Remove the upper lid (40).
9	Take out the diaphragm unit (43, 44, 45, 46, 47).
10	Unscrew the nut (47).
11	Remove the diaphragm protection disc (44).
12	Remove and replace the diaphragm (43), taking care to lubricate the lanyard with synthetic grease. <b>NOTE!</b> <b>Before inserting the replacement diaphragm, clean the retaining slots with a cleaning solution.</b>
13	Fit the diaphragm protection disc (44).
14	Place and fix the nut (47) according to the following tightening torque: • Mod. 102 > tab. 9.58.
15	Remove the ring (49).
16	Undo and remove the screws (48).
17	Remove the lower lid (41).
18	Remove the O-ring (50) from the nut (49) and replace it, taking care to lubricate it with synthetic grease. <b>NOTE!</b> <b>Before inserting the replacement O-ring, clean the retaining slots with a cleaning solution.</b>
19	Remove the bush (35).
20	Remove the O-ring (27) from the bush (35) and replace it, taking care to lubricate it with synthetic grease. <b>NOTE!</b> <b>Before inserting the replacement O-ring, clean the retaining slots with a cleaning solution.</b>



Pressure switch Mod. 102M/102MH

Step	Action
21	<p>Remove the U-shaped ring (4) from the bush (35) and replace it, taking care to lubricate it with synthetic grease.</p> <p><b>NOTE!</b>  <b>Before inserting the replacement U-ring, clean the retaining slots with a cleaning solution.</b></p>
22	<p>Position the bush (35) together with the O-ring (27).</p> <p><b>NOTE!</b>  <b>Before inserting the bush (35), lubricate the inner surface with silicone grease.</b></p>
23	<p>Fit the lower lid (41).</p> <p><b>NOTE!</b>  <b>Make sure there is a gasket between the lower lid and the pressure switch body.</b></p>
24	<p>Insert and fix the screws (48) according to the following tightening torque:</p> <ul style="list-style-type: none"> <li>• Mod. 102 &gt; tab. 9.58.</li> </ul> <p><b>NOTE!</b>  <b>Tighten the screws according to the cross diagram in paragraph 9.4.2.2.</b></p>
25	Insert the ring (49).
26	Put the diaphragm unit in place (43, 44, 45, 46, 47).
27	Fit the lid (40).
28	<p>Insert and fix the screws (42) according to the following tightening torque:</p> <ul style="list-style-type: none"> <li>• Mod. 102 &gt; tab. 9.58.</li> </ul> <p><b>NOTE!</b>  <b>Tighten the screws according to the cross diagram in paragraph 9.4.2.2.</b></p>
29	<p>Completely release the maximum pressure spring (11) by turning the ring nut (13).</p> <p><b>NOTE!</b>  <b>To calibrate the spring, please refer to chapter 13 “Calibration tables”.</b></p>
30	<p>Completely release the minimum pressure spring (17) by turning the ring nut (15).</p> <p><b>NOTE!</b></p> <ul style="list-style-type: none"> <li>• <b>To calibrate the spring, please refer to chapter 13 “Calibration tables”;</b></li> <li>• <b>If any.</b></li> </ul>
31	Insert and fix the cap (18).

Tab. 1.67.

**WARNING!**

**Ensure that all parts have been fitted correctly.**

1.4.6.2 - PRESSURE SWITCH MOD. 103M/103MH

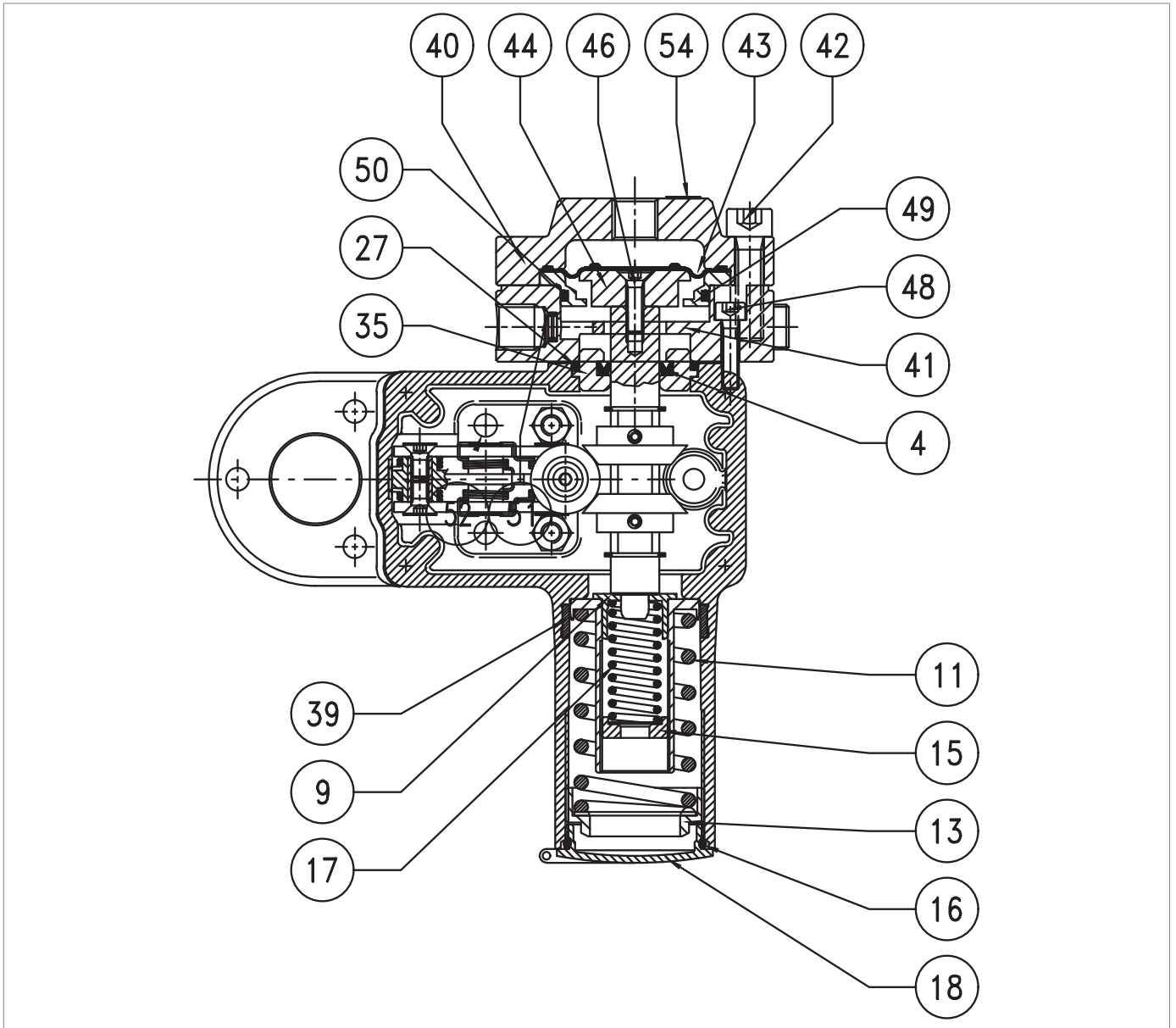
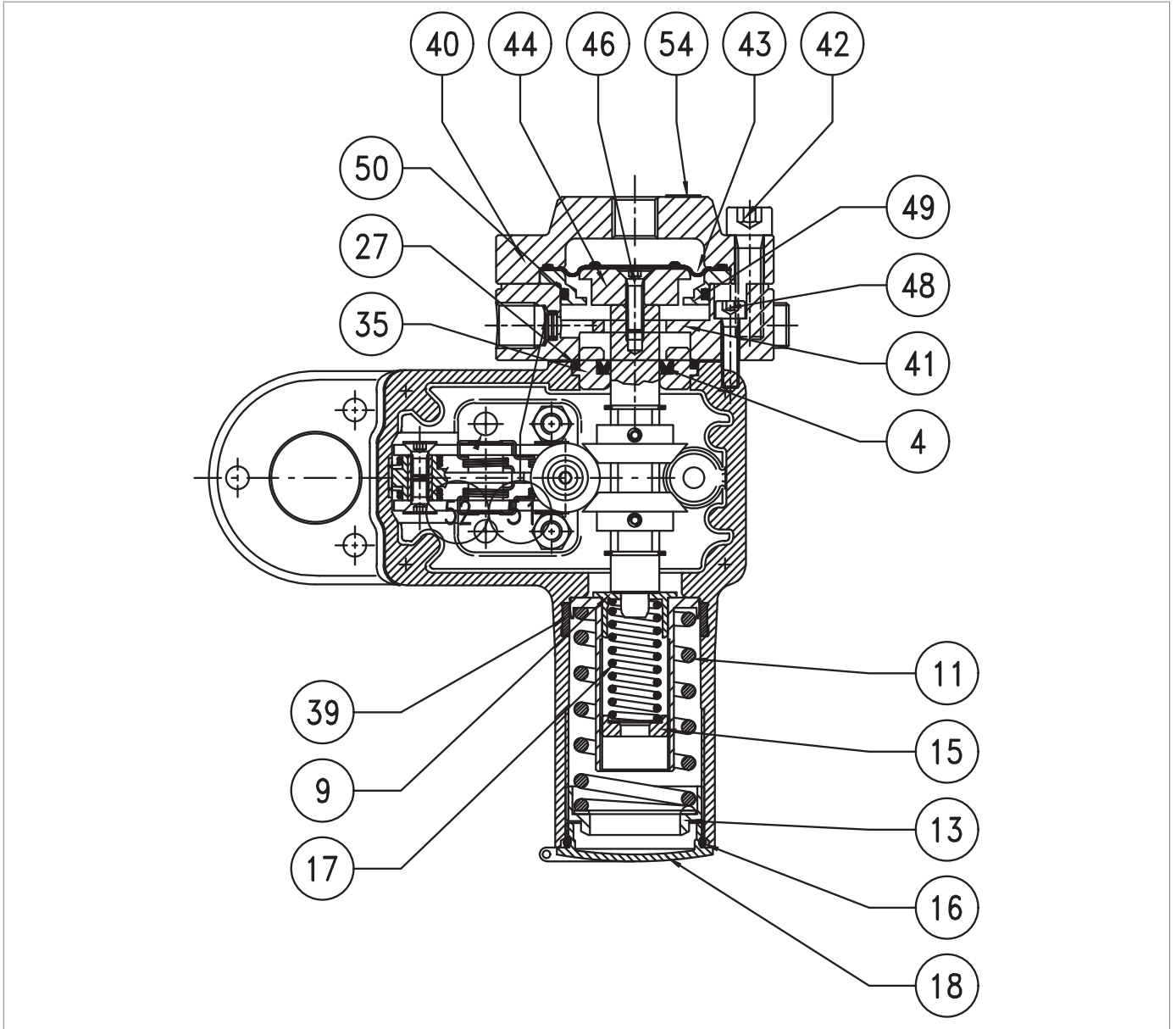

Fig. 1.28. Pressure switch Mod. 103M/103MH

Step	Action
1	Unscrew and remove the cap (18).
2	Remove the O-ring (16) from the lid (18) and replace it, taking care to lubricate it with synthetic grease. <b>NOTE!</b> <b>Before inserting the replacement O-ring, clean the retaining slots with a cleaning solution.</b>
3	Completely release the spring (11) by turning the ring nut (13).
4	Completely release the minimum pressure spring (17) by adjusting the ring nut (15). <b>NOTE!</b> <b>The minimum spring may not be present.</b>
5	Remove the ring nut (13), the spring (11) and the spring support (17).
6	Remove the I/DWR ring (39) from the pressure switch sleeve and replace it, taking care to lubricate it with synthetic grease. <b>NOTE!</b> <b>Before inserting the replacement I/DWR ring, clean the retaining slots with a cleaning solution.</b>
7	Undo and remove the screws (42).
8	Remove the upper lid (40).
9	Remove and replace the diaphragm (43), taking care to lubricate the lanyard with synthetic grease. <b>NOTE!</b> <b>Before inserting the replacement diaphragm, clean the retaining slots with a cleaning solution.</b>
10	Undo and remove the screws (46).
11	Remove the diaphragm protection disc (44).
12	Remove the ring (49).
13	Remove the O-ring (50) from the ring (49) and replace it. <b>NOTE!</b> <b>Before inserting the replacement O-ring, clean the retaining slots with a cleaning solution.</b>
14	Undo and remove the screws (48).
15	Remove the lower lid (41).
16	Remove the bush (35).
17	Remove the O-ring (27) from the bush (35) and replace it, taking care to lubricate it with synthetic grease. <b>NOTE!</b> <b>Before inserting the replacement O-ring, clean the retaining slots with a cleaning solution.</b>
18	Remove the U-shaped ring (4) from the bush (35) and replace it, taking care to lubricate it with synthetic grease. <b>NOTE!</b> <b>Before inserting the replacement U-ring, clean the retaining slots with a cleaning solution.</b>



Pressure switch Mod. 103M/103MH



Step	Action
19	Position the bush (35) together with the O-ring (27). <b>NOTE!</b> <b>Before inserting the bush (35), lubricate the inner surface with silicone grease.</b>
20	Remove the lower lid (41)
21	Insert and fix the screws (48) according to the following tightening torque: • Mod. 103M/103MH > tab. 9.59. <b>NOTE!</b> • <b>Tighten the screws according to the cross diagram in paragraph 9.4.2.2;</b> • <b>Make sure there is a gasket between the lower lid and the pressure switch body.</b>
22	Insert the ring (49).
23	Fit the diaphragm protection disc (44).
24	Insert and fix the screws (46) according to the following tightening torque: • Mod. 103M/103MH > tab. 9.59. <b>NOTE!</b> • <b>Tighten the screws according to the cross diagram in paragraph 9.4.2.2;</b> • <b>Before inserting the screw (46), apply thread locking glue.</b>
25	Fit the diaphragm (43).
26	Fit the lid (40).
27	Insert and fix the screws (42) according to the following tightening torque: • Mod. 103M/103MH > tab. 9.59. <b>NOTE!</b> <b>Tighten the screws according to the cross diagram in paragraph 9.4.2.2.</b>
28	Completely release the maximum pressure spring (11) by turning the ring nut (13). <b>NOTE!</b> <b>To calibrate the spring, please refer to chapter 13 “Calibration tables”.</b>
29	Completely release the minimum pressure spring (17) by turning the ring nut (15). <b>NOTE!</b> • <b>To calibrate the spring, please refer to chapter 13 “Calibration tables”;</b> • <b>If any.</b>
30	Insert and fix the cap (18).

Tab. 1.68.

**WARNING!**

**Ensure that all parts have been fitted correctly.**

**1.4.6.3 - PRESSURE SWITCH MOD. 104M/104MH - 105M/105MH**

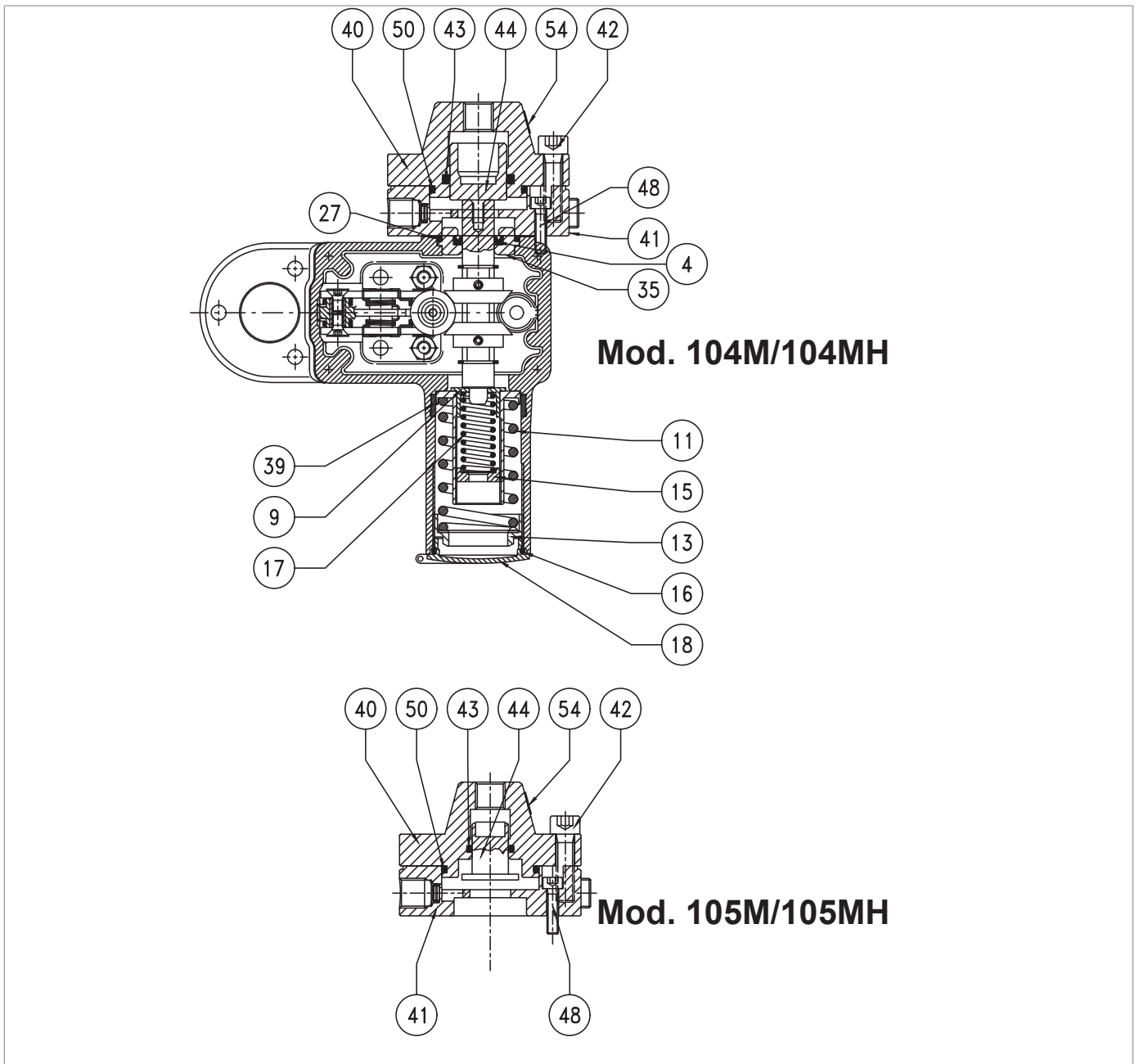

Fig. 1.29. Pressure switch Mod. 104M/104MH - 105M/105MH

Step	Action
1	Unscrew and remove the cap (18).
2	Remove the O-ring (16) from the lid (18) and replace it, taking care to lubricate it with synthetic grease. <b>NOTE!</b> <b>Before inserting the replacement O-ring, clean the retaining slots with a cleaning solution.</b>
3	Completely release the spring (11) by turning the ring nut (13).
4	Completely release the minimum pressure spring (17) by adjusting the ring nut (15). <b>NOTE!</b> <b>The minimum spring may not be present.</b>
5	Remove the ring nut (13), the spring (11) and the spring support (17).
6	Remove the I/DWR ring (39) from the pressure switch sleeve and replace it, taking care to lubricate it with synthetic grease. <b>NOTE!</b> <b>Before inserting the replacement I/DWR ring, clean the retaining slots with a cleaning solution.</b>
7	Undo and remove the screws (42).
8	Remove the upper lid (40) together with the piston (44).
9	Pull the piston (44) out of the upper lid (40).
10	Remove the O-rings (43, 50) from the upper lid (40) and replace it, taking care to lubricate it with synthetic grease. <b>NOTE!</b> <b>Before inserting the replacement O-rings, clean the retaining slots with a cleaning solution.</b>
11	Refit the piston (44) into the upper lid (40).
12	Undo and remove the screws (48).
13	Remove the lower lid (41).
14	Remove the bush (35).
15	Remove the O-ring (27) from the bush (35) and replace it, taking care to lubricate it with synthetic grease. <b>NOTE!</b> <b>Before inserting the replacement O-ring, clean the retaining slots with a cleaning solution.</b>
16	Remove the U-shaped ring (4) from the bush (35) and replace it, taking care to lubricate it with synthetic grease. <b>NOTE!</b> <b>Before inserting the replacement U-ring, clean the retaining slots with a cleaning solution.</b>
17	Position the bush (35) together with the O-ring (27). <b>NOTE!</b> <b>Before inserting the bush (35), lubricate the inner surface with silicone grease.</b>

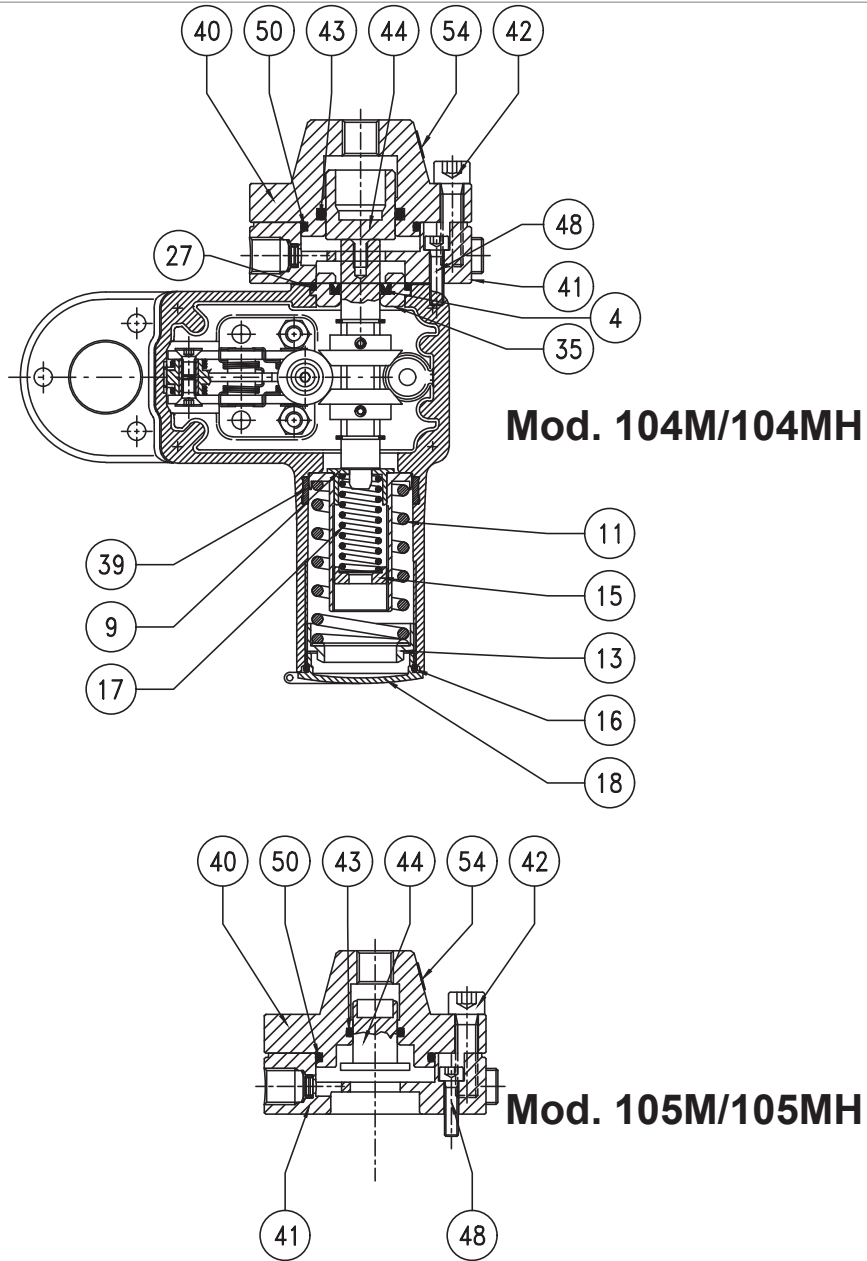







Fig. 1.30. Pressure switch Mod. 104M/104MH - 105M/105MH

Step	Action
18	Fit the lower lid (41). <div style="border: 1px solid black; padding: 5px;">  <b>NOTE!</b>  <b>Make sure that the gasket is in place.</b> </div>
19	Insert and fix the screws (48) according to the following tightening torques: <ul style="list-style-type: none"> <li>• Mod. 104M/104MH - 105M/105MH &gt; tab. 9.60</li> </ul> <div style="border: 1px solid black; padding: 5px;">  <b>NOTE!</b>  <b>Tighten the screws according to the cross diagram in paragraph 9.4.2.2.</b> </div>
20	Fit the upper lid (40).
21	Insert and fix the screws (42) according to the following tightening torques: <ul style="list-style-type: none"> <li>• Mod. 104M/104MH - 105M/105MH &gt; tab. 9.60</li> </ul> <div style="border: 1px solid black; padding: 5px;">  <b>NOTE!</b>  <b>Tighten the screws according to the cross diagram in paragraph 9.4.2.2.</b> </div>
22	Completely release the maximum pressure spring (11) by turning the ring nut (13). <div style="border: 1px solid black; padding: 5px;">  <b>NOTE!</b>  <b>To calibrate the spring, please refer to chapter 13 “Calibration tables”.</b> </div>
23	Completely release the minimum pressure spring (17) by turning the ring nut (15). <div style="border: 1px solid black; padding: 5px;">  <b>NOTE!</b>  <ul style="list-style-type: none"> <li>• <b>To calibrate the spring, please refer to chapter 13 “Calibration tables”;</b></li> <li>• <b>If any.</b></li> </ul> </div>
24	Insert and fix the cap (18).

Tab. 1.69.

 **WARNING!**

**Ensure that all parts have been fitted correctly.**

1.4.6.4 - VALVE 3/2

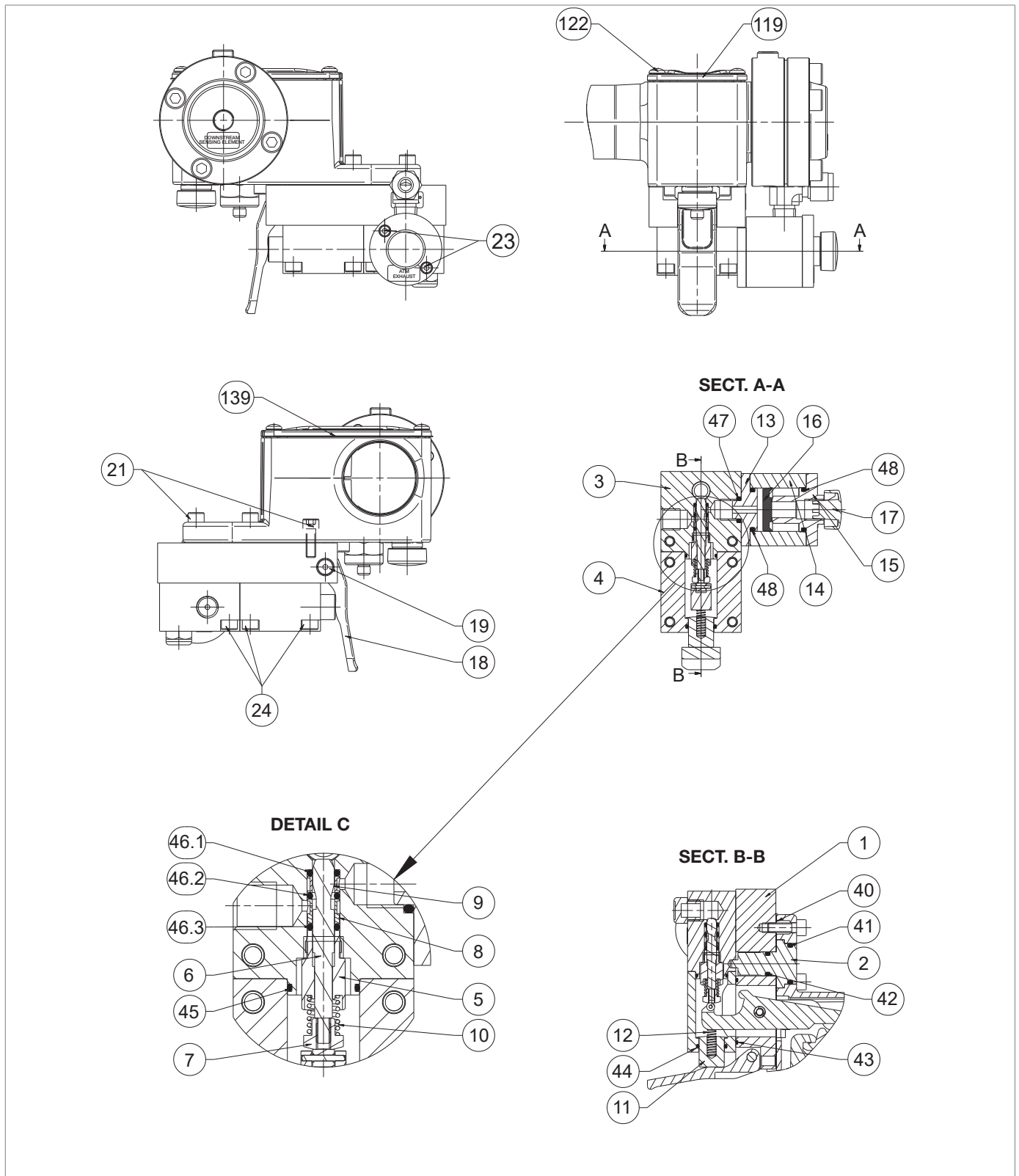





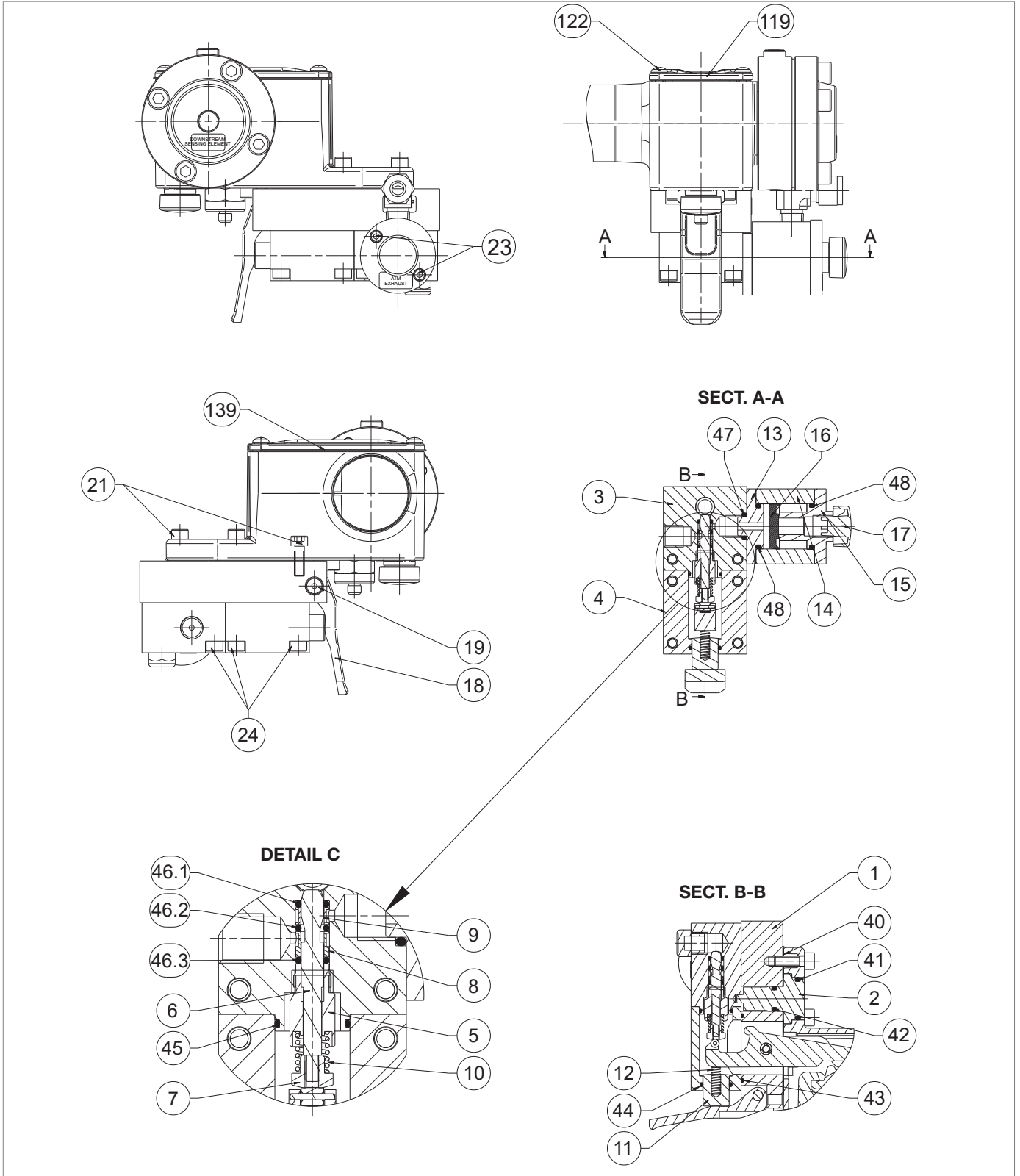

Fig. 1.31. Valve 3/2

Step	Action
1	 <b>NOTE!</b> <b>Make sure the slam-shut device is set to “OFF”.</b>
2	Undo and remove the screws (122) of the pressure switch lid (119).
3	Remove the pressure switch lid (119) together with the gasket (139).
4	Turn the device upside down.
5	Undo and remove the screw (19) and the lever (18).
6	Undo and remove the screws (23).
7	Remove the quick discharge assembly (13, 14, 15, 17).
8	Remove the O-ring (47) from the valve body (3) and lubricate it with synthetic grease.  <b>NOTE!</b> <b>Before inserting the replacement O-ring, clean the retaining slots with a cleaning solution.</b>
9	Remove the locking flange (15).
10	Remove the O-ring (48) from the closing flange (15) and replace it, taking care to lubricate it with synthetic grease.  <b>NOTE!</b> <b>Before inserting the replacement O-ring, clean the retaining slots with a cleaning solution.</b>
11	Remove and replace the gasket (16), lubricating it with synthetic grease.  <b>NOTE!</b> <b>Orient the lip of the seal (16) towards the lid (15).</b>
12	Remove the intermediate flange (13).
13	Remove the O-ring (48) from the intermediate flange (13) and replace it, taking care to lubricate it with synthetic grease.  <b>NOTE!</b> <b>Before inserting the replacement O-ring, clean the retaining slots with a cleaning solution.</b>
14	Undo and remove the screws (24).
15	Lift the valve body (3) together with the valve lid (4).
16	Separate the valve body (3) from the valve lid (4).
17	Remove the O-ring (45) from the valve lid (3) and lubricate it with synthetic grease.  <b>NOTE!</b> <b>Before inserting the replacement O-ring, clean the retaining slots with a cleaning solution.</b>
18	Pull out the button (11) together with the spring (12),
19	Remove the O-ring (44) from the valve lid (4) and lubricate it with synthetic grease.  <b>NOTE!</b> <b>Before inserting the replacement O-ring, clean the retaining slots with a cleaning solution.</b>
20	Fit the button (11) together with the spring (12).
21	Unscrew and remove the stem assembly (5, 6, 7, 8, 9, 10).





Valve 3/2

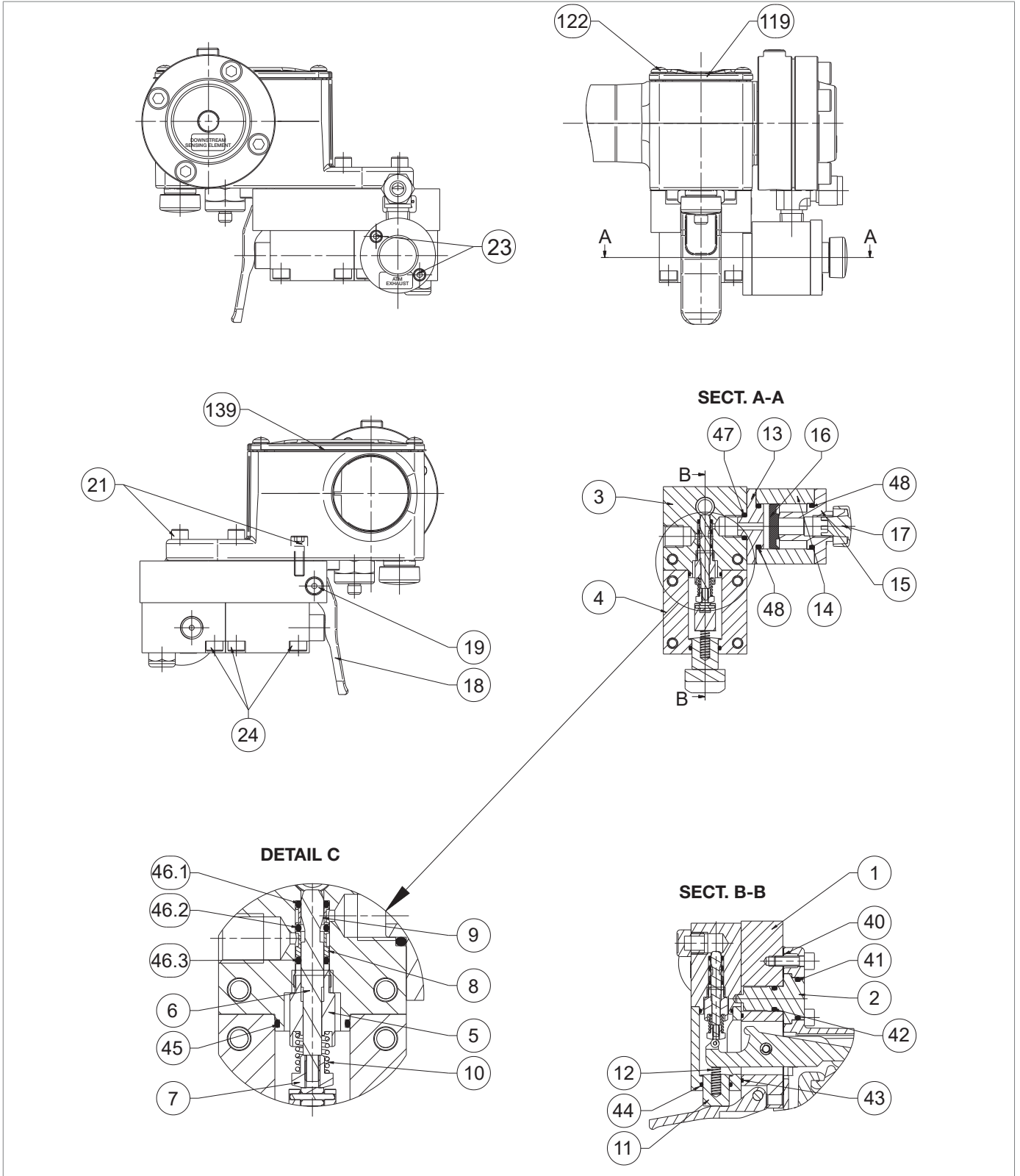

Step	Action
22	Remove the O-ring (46.3) and the bush (8).
23	Remove the O-ring (46.2) and the bush (9).
24	Take out the O-ring (46.1).
25	<p>Replace the O-rings (46.1, 46.2 and 46.3) and lubricate them with synthetic grease.</p> <div style="border: 1px solid blue; padding: 5px;"> <p><b>! NOTE!</b>  <b>Before inserting the replacement O-rings, clean the retaining slots with a cleaning solution.</b></p> </div>
26	<p>Remove the O-ring (46.1) and the perforated bush (9).</p> <div style="border: 1px solid blue; padding: 5px;"> <p><b>! NOTE!</b>  <b>Use the equipment (P) referred to in table 7.33.</b></p> </div>
27	<p>Insert the O-ring (46.2) and the perforated bush (8).</p> <div style="border: 1px solid blue; padding: 5px;"> <p><b>! NOTE!</b></p> <ul style="list-style-type: none"> <li>• <b>Use the equipment (P) referred to in table 7.33.</b></li> <li>• <b>Align the bush (8) as shown in detail (C)</b></li> </ul> </div>
28	<p>Insert the o-ring (46.3).</p> <div style="border: 1px solid blue; padding: 5px;"> <p><b>! NOTE!</b>  <b>Use the equipment (P) referred to in table 7.33.</b></p> </div>
29	Insert and press the equipment (P) together with the O-rings (46.1, 46.2, 46.3) and the perforated bushes (8, 9) into the valve body (3).
30	Remove the equipment (P).
31	Insert and screw the stem assembly (5, 6, 7, 8, 9, 10).
32	<p>Remove the O-ring (43) from the valve bracket (1) and replace it, taking care to lubricate it with synthetic grease.</p> <div style="border: 1px solid blue; padding: 5px;"> <p><b>! NOTE!</b>  <b>Before inserting the replacement O-ring, clean the retaining slots with a cleaning solution.</b></p> </div>
33	Turn the device upside down.
34	Undo and remove the outer screws (21).
35	Undo and remove the inner screws (21).
36	Lift the pressure switch.
37	Remove the centring pin (2).
38	<p>Remove the O-rings (41, 42) from the centring pin (2) and replace them, taking care to lubricate them with synthetic grease.</p> <div style="border: 1px solid blue; padding: 5px;"> <p><b>! NOTE!</b>  <b>Before inserting the replacement O-rings, clean the retaining slots with a cleaning solution.</b></p> </div>
39	Remove and replace the gasket (40).
40	Fit the centring pin (2) on the valve bracket (1).
41	Assemble the pressure switch to the valve bracket (1).
42	Insert and fix the screws (21).
43	Insert and fix the internal screws (21).
44	Turn the device upside down.



Valve 3/2

Step	Action
45	Insert the valve lid (4) so that the spring (12) rests on the lever of the pressure switch.  <b>NOTE!</b> <b>Keep the valve lid (4) tilted for easier assembly.</b>
46	Push and tilt the valve lid upwards (4).
47	Insert the valve body (3) together with the stem assembly (5, 6, 7, 8, 9, 10) into the valve lid (4).  <b>NOTE!</b> <b>The valve body (3) must be centred with the centring pin (2).</b>
48	Fasten the screws (24) of the valve body (3).
49	Fasten the screws (24) of the valve lid (4).
50	Fit the lever (18).
51	Insert and fix the screws (19).
52	Insert the flange (15) into the cylinder (14).
53	Insert the gasket (16) into the cylinder (14) with the flat side facing upwards.
54	Insert the flange (13) into the cylinder (14).
55	Insert the screws (23).
56	Fit the quick discharge assembly (13, 14, 15, 17) into the valve body (3).
57	Fix the screws (23).
58	Fit the lid (119) together with the gasket (139).
59	Insert and fix the screws (122) of the pressure switch.

Tab. 1.70.

 **WARNING!**

**Ensure that all parts have been fitted correctly.**

**1.4.7 - LINE OFF 2.0 RECONNECTION PROCEDURE**

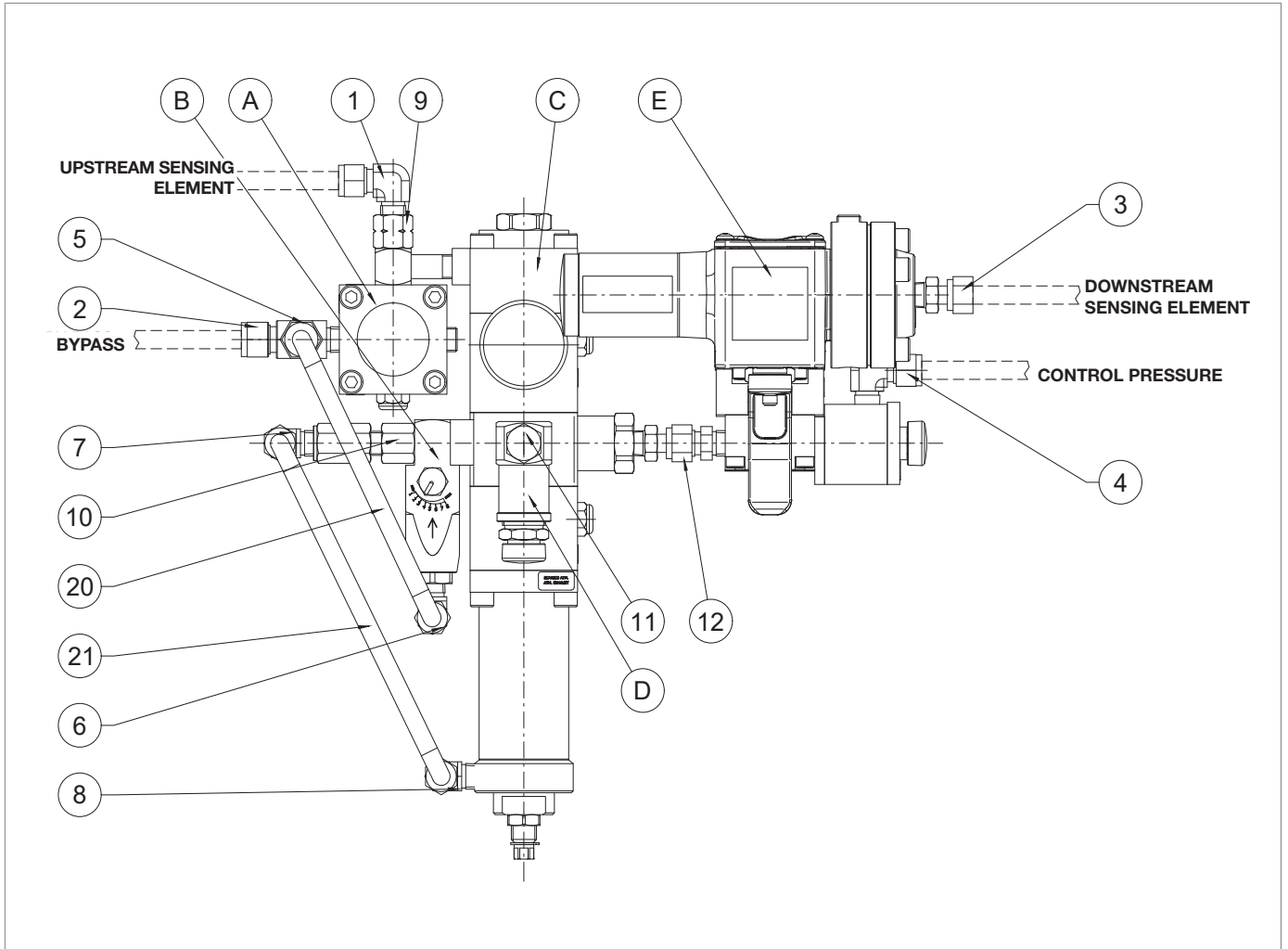

Fig. 1.32. LINE OFF 2.0

At the end of maintenance, reconnect the LINE OFF 2.0 device as shown in table 9.71.

Step	Action
1	Remove assembly "E" (valve <b>3/2</b> and control device) from assembly "C" (regulator <b>R44/SS</b> ) together with the fitting (12).
2	Remove assembly "D" (safety valve <b>VS/FI</b> ) together with the fitting (11).
3	Remove assembly "B" (lamination valve <b>AR100</b> ) together with the fitting (10).
4	Remove assembly "A" (bypass device <b>HP2/2</b> ) together with the fitting (9).
5	Reconnect the pipe (21) together with the fittings (7, 8).
6	Reconnect the pipe (20) together with the fittings (5, 6).
7	Insert and tighten the fixing screw to put the LINE OFF 2.0 in place.
8	Reconnect the pipes together with the fittings (1, 2, 3, 4).

Tab. 1.71.

#### 1.4.8 - PROCEDURE FOR RECOMMISSIONING AFTER MAINTENANCE



#### NOTE!

**For the recommissioning procedure, refer to the relevant paragraph.**



## 10 - TROUBLESHOOTING

Below is a list of the cases (causes and services) that may occur over time in the form of malfunctions of various kinds. These situations depend on the conditions of the gas as well as on the natural ageing and wear of the materials.

### 10.1 - GENERAL WARNINGS

#### **HAZARD!**

**Maintenance work must be carried out by qualified personnel:**

- trained on workplace safety also based on the regulations in force in the place of installation of the work equipment;
- qualified and authorised to carry out activities related to the equipment.

#### **WARNING!**





**PIETRO FIORENTINI S.p.A. shall not be held liable for any damage to people and property due to services:**

- other than those described;
- performed according to methods other than those specified;
- carried out by unsuitable personnel.

#### **NOTE!**

**If an operating fault occurs and qualified personnel are not available for the specific service, call the Authorised Assistance Centre of PIETRO FIORENTINI S.p.A.**

## 10.2 - OPERATOR QUALIFICATION SPECIFICATION

Commissioning	
<b>Operator qualification</b>	<ul style="list-style-type: none"> <li>• Mechanical maintenance technician;</li> <li>• Electrical maintenance technician;</li> <li>• Installer;</li> <li>• Name of the user.</li> </ul>
<b>PPE required</b>	<div style="display: flex; align-items: center; gap: 5px;">      </div> <div style="background-color: #f4a460; padding: 5px; margin-top: 5px;"> <p><b>⚠ WARNING!</b></p> <p>The PPE listed in this table is related to the risk associated with the equipment. For the PPE required to protect against risks associated with the workplace, installation or operating conditions, please refer to:</p> <ul style="list-style-type: none"> <li>• the regulations in force in the country of installation;</li> <li>• <u>any information provided by the Safety Manager at the installation facility.</u></li> </ul> </div>
<b>Equipment required</b>	Refer to chapter 7 “Equipment for commissioning/maintenance”.

Tab. 10.72.

## 10.3 - TROUBLESHOOTING PROCEDURES

For proper troubleshooting, proceed as follows:

- close the downstream shut-off valves;
- refer to the troubleshooting tables listed below.



## 10.4 - HBC 975 TROUBLESHOOTING TABLES

### WARNING!

If the slam-shut valve triggered, before any other operation, close the inlet and outlet valves (V1 and V2) of the line and discharge pressure.

### NOTE!

To consult the image of the slam-shut valve, refer to chapter 9.4.3 "HBC 975 slam-shut valve maintenance procedure".

Failure	Device	Possible causes	Service
<b>Incorrect tripping pressure</b>	PRESSURE SWITCH MOD. 100	Max. and/or min. pressure spring incorrect calibration.	Repeat calibration by adjusting the ring nuts
		Leverages with friction	Clean and lubricate the levers and if necessary replace the pressure switch
		Springs (11,17) collapsed	Replace
		Springs (11,17) out of level	Refit
<b>Impossible to reset</b>	HB/97 SLAM-SHUT DEVICE	Stem (6) locked due to friction	Clean and lubricate
		Stem (6) locked in closing position	Clean and lubricate
		Plug (71) locked due to friction	Clean and lubricate
		"U-shaped" ring (63) damaged	Replace
		I/DWR ring (64) damaged	Replace
	PRESSURE SWITCH MOD. 100	Wrong max and/or min spring calibration.	Repeat calibration by adjusting the ring nuts
		The downstream pressure is not consistent with the min and/or max setting of the slam-shut device	Adjust the downstream pressure
		Leverages with friction	Clean and lubricate the levers if needed replace the pressure switch
		Diaphragm breakage (43) if a min. pressure spring is installed.	Replace
		Manual release button locked	Clean and lubricate
	HP2/2	Filter (11) clogged	Replace

Failure	Device	Possible causes	Service
<b>Locking delay</b>	AR100	Filter (5) clogged	Replace
	R44/SS	Lower diaphragm (16) breakage	Replace
		Upper diaphragm (16) breakage	Replace
		Upper O-ring (53) not sealing	Clean and replace if needed
		Lower O-ring (53) not sealing	Clean and replace if needed
		O-ring (11) not sealing	Clean and replace if needed
		O-ring (35) not sealing	Clean and replace if needed
		Balancing piston (42) locked	Clean and lubricate
		O-ring (62) not sealing	Clean and replace if needed
	VS/FI	No sealing	Check and clean if necessary
	VALVE 3/2	Outer O-rings (46) not sealing	Clean and replace if needed
		O-ring (47) not sealing	Clean and replace if needed
		O-ring (48) not sealing	Clean and replace if needed
		Pad (16) dirty or damaged	Clean and replace if needed
	HB/97 SLAM-SHUT DE- VICE	Stem (6) with friction	Clean and lubricate
Plug (71) with friction		Clean and lubricate	
Balancing piston O-ring (36) not sealing		Clean and replace if needed	
VALVE 3/2	Gasket (16) locked	Clean and replace if needed	
	Clogged vents	Check and clean if necessary	
<b>Failure to provide service</b>	HB/97	Stem (6) locked in opening position	Clean and lubricate
		Plug (71) locked in opening position	Clean and lubricate
		Die O-ring (36)	Clean and replace if needed
		I/DWR ring (64) damaged	replace
	PRESSURE SWITCH MOD.100	Diaphragm breakage (43) if there is no min. pressure spring.	Replace
		Locked levers	Check and if necessary clean and lubricate
	VALVE 3/2	Pin (6) locked	Check and if necessary clean and lubricate
		Lip pad (16) locked	Clean and replace if needed
		Clogged vents	Check and clean if needed

Failure	Device	Possible causes	Service
<b>Unintentional operation</b>	HB/97	O-ring (40) not sealing	Clean and replace if needed
		O-ring (36) not sealing	Clean and replace if needed
		Upper O-ring (39) not sealing	Clean and replace if needed
		No sealing of the "U" ring (63)	Clean and replace if needed
		Upper O-ring (43) not sealing	Clean and replace if needed
		Upper O-ring (62) not sealing	Clean and replace if needed
		Upper O-ring (42) not sealing	Clean and replace if needed
	R44/SS	Lower diaphragm (16) not sealing	Clean and replace if needed
		O-ring (28) not sealing	Clean and replace if needed
		O-ring (29) not sealing	Clean and replace if needed
		O-ring (26.1) not sealing	Clean and replace if needed
	VS/FI	Lack of Pad seal (3)	Clean and replace if needed
	VALVE 3/2	Gasket (16) locked	Clean and replace if needed
Outer O-rings (46) not sealing		Clean and replace if needed	
O-ring (47) not sealing		Clean and replace if needed	
O-ring (48) not sealing		Clean and replace if needed	
<b>Downstream pressure increase with slam-shut device closing</b>	HB/97	Reinforced gasket (8) dirty or damaged	Clean and replace if needed
		Upper O-ring (39) not sealing	Clean and replace if needed
		Plug profile (71) damaged	Replace
		O-ring (88) not sealing	Clean and replace if needed
		O-ring (87) not sealing	Clean and replace if needed
	HP2/2	Upper O-ring (21) not sealing	Clean and replace if needed
		Damaged seat profile (6)	Replace
		Pad (12) dirty or damaged	Clean and replace if needed
		Upper O-ring (24) not sealing	Clean and replace if needed

Tab. 10.73.



## 11 - UNINSTALLATION AND DISPOSAL

### 11.1 - GENERAL SAFETY WARNINGS

#### HAZARD!



Make sure that there are no potentially explosive ignition sources in the work area set up to uninstall and/or dispose of the equipment.

#### WARNING!

Before proceeding with uninstallation and disposal, make the equipment safe by disconnecting it from any power supply.

### 11.2 - QUALIFICATION OF THE OPERATORS IN CHARGE

#### Commissioning

Operator qualification	Installer
PPE required	 <p> <b>WARNING!</b></p> <p>The PPE listed in this table is related to the risk associated with the equipment. For the PPE required to protect against risks associated with the workplace, installation or operating conditions, please refer to:</p> <ul style="list-style-type: none"> <li>• the regulations in force in the country of installation;</li> <li>• any information provided by the Safety Manager at the installation facility.</li> </ul>
Equipment required	Refer to chapter 7 “Equipment for commissioning/maintenance”.

Tab. 11.74.

### 11.3 - UNINSTALLATION

#### ATTENTION!

Before uninstalling the equipment, completely drain the fluid in the reduction line and inside the equipment.

#### NOTE!

To uninstall the equipment, refer to the installation steps (see chapter 6 “Installation”) and proceed in reverse order.

### 11.4 - INFORMATION REQUIRED IN CASE OF RE-INSTALLATION

#### NOTE!

Should the equipment be reused after uninstallation, refer to chapters:

- 6 “Installation”;
- 8 “Commissioning”.

## 11.5 - DISPOSAL INFORMATION

### NOTE!

**Bear in mind that the laws in force in the country of installation must be complied with. Illegal or improper disposal involves the application of the penalties provided for by the legislation in force in the country of installation.**

### NOTE!

**Proper disposal prevents damage to humans and the environment and promotes the reuse of precious raw materials.**

The equipment was manufactured with materials that can be recycled by specialised companies. For proper disposal of the equipment, proceed as specified in table 11.75:

Step	Action
1	Set up a large work area free from obstacles where to safely dismantle the equipment.
2	Sort the various components by type of material for easier recycling through separate collection.
3	Send the materials obtained in <b>Step 2</b> to a specialised company.

Tab. 11.75.

The equipment in any configuration consists of the following materials:

Material	Disposal/recycling indications
<b>Plastic</b>	It must be dismantled and disposed of separately.
<b>Lubricants/Oils</b>	They must be collected and delivered to the appropriate specialised and authorised collection and disposal centres.
<b>Steel</b>	Disassemble and collect separately. It must be recycled through the specific collection centres.
<b>Stainless steel</b>	Disassemble and collect separately. It must be recycled through the specific collection centres.
<b>Aluminium</b>	Disassemble and collect separately. It must be recycled through the specific collection centres.
<b>Pneumatic/electric components</b>	They must be dismantled in order to be reused if they are still in good condition or, if possible, overhauled and recycled.

Tab. 11.76.

### NOTE!

**Refer to chapter 9 “Maintenance and functional checks” to better identify the composition of the equipment and its parts.**

## 12 - RECOMMENDED SPARE PARTS

### 12.1 - GENERAL WARNINGS

 **NOTE!**

If non-original spare parts are used, PIETRO FIORENTINI S.p.A. their declared performance cannot be guaranteed.

It is recommended to use PIETRO FIORENTINI S.p.A. original spare parts.

PIETRO FIORENTINI S.p.A. shall not be held liable for any damage caused by using non-original parts.

### 12.2 - HOW TO REQUEST SPARE PARTS

 **NOTE!**

For specific information, please refer to the sales network of PIETRO FIORENTINI S.p.A.





## 13 - CALIBRATION TABLES

### 13.1 - CALIBRATION TABLES FOR PRESSURE SWITCHES MOD. 100

Below are the calibration tables for the pressure switches that may be installed in the built-in slam-shut valves:

Mod. 102M/102MH - Max pressure							
Pos.	Spring item code	Spring colour	d	Lo	De	Min.	Max
1	2701260	White	3.5	60	35	0.2	0.8
2	2701530	Yellow	4			0.801	1.6
3	2701790	Yellow/black	4.5			1.601	2.6
4	2702280	White/red	5.5			2.601	5.5

d = Wire Diameter (mm) Lo = Spring Length (mm) De = External Diameter (mm) Min./Max. = Pressure (bar)

Tab. 13.77.

Mod. 102M - Min pressure							
Pos.	Spring item code	Spring colour	d	Lo	De	Min.	Max
1	2700713	Green	2.3	40	15	0.2	0.4
2	2700750	Black	2.5			0.401	0.8
3	2700985	Brown	3			0.801	2.8

d = Wire Diameter (mm) Lo = Spring Length (mm) De = External Diameter (mm) Min./Max. = Pressure (bar)

Tab. 13.78.

Mod. 102MH - Min pressure								
Pos.	Spring item code	Spring colour	d	Lo	De	Min.	Max	
1	2700985	Brown	3	40	15	2.8	4.2	
	2700980	Blue	3	35				
2	2700985	Brown	3	40		15	4.201	5.5
	2700985	Brown	3					

d = Wire Diameter (mm) Lo = Spring Length (mm) De = External Diameter (mm) Min./Max. = Pressure (bar)

Tab. 13.79.

**Mod. 103M/103MH - Max pressure**

Pos.	Spring item code	Spring colour	d	Lo	De	Min.	Max
1	2701530	Yellow	4	60	35	2	4
2	2701790	Yellow/black	4.5	60		4.001	7.5
3	2702280	White/red	5.5	60		7.501	15
4	2702454	Fuchsia	6	70		15.001	22

d = Wire Diameter (mm) Lo = Spring Length (mm) De = External Diameter (mm) Min./Max. = Pressure (bar)

*Tab. 13.80.*
**Mod. 103M - Min pressure**

Pos.	Spring item code	Spring colour	d	Lo	De	Min.	Max
1	2700464	Orange	1.7	40	15	0.2	0.5
2	2700513	Red	2			0.501	0.8
3	2700713	Green	2.3			0.801	1.7
4	2700750	Black	2.5			1.701	4
5	2700985	Brown	3			4.001	8

d = Wire Diameter (mm) Lo = Spring Length (mm) De = External Diameter (mm) Min./Max. = Pressure (bar)

*Tab. 13.81.*
**Mod. 103MH - Min pressure**

Pos.	Spring item code	Spring colour	d	Lo	De	Min.	Max
1	2700985	Brown	3	40	15	8	13
	2700980	Blue	3	35			
2	2700985	Brown	3	40	15	13.001	19
	2700985	Brown	3				

d = Wire Diameter (mm) Lo = Spring Length (mm) De = External Diameter (mm) Min./Max. = Pressure (bar)

*Tab. 13.82.*
**Mod. 104M/104MH - Max pressure**

Pos.	Spring item code	Spring colour	d	Lo	De	Min.	Max
1	2702280	White/Red	5.5	60	35	15.001	30
2	2702454	Fuchsia	6	70		30.001	45

d = Wire Diameter (mm) Lo = Spring Length (mm) De = External Diameter (mm) Min./Max. = Pressure (bar)

*Tab. 13.83.*

Mod. 104MH - Min pressure								
Pos.	Spring item code	Spring colour	d	Lo	De	Min.	Max	
1	2700985	Brown	3	40	15	18	30	
	2700980	Blue	3	35				
2	2700985	Brown	3	40		15	30.001	41
	2700985	Brown	3					

d = Wire Diameter (mm) Lo = Spring Length (mm) De = External Diameter (mm) Min./Max. = Pressure (bar)

Tab. 13.84.

Mod. 105M/105MH - Max pressure							
Pos.	Spring item code	Spring colour	d	Lo	DE	Min.	Max
1	2702280	White/Red	5.5	60	35	30	60
2	2702454	Fuchsia	6	70		60.001	90

d = Wire Diameter (mm) Lo = Spring Length (mm) De = External Diameter (mm) Min./Max. = Pressure (bar)

Tab. 13.85.

